

Cat. No. I546-E1-01  
0675398-6

**OMRON**

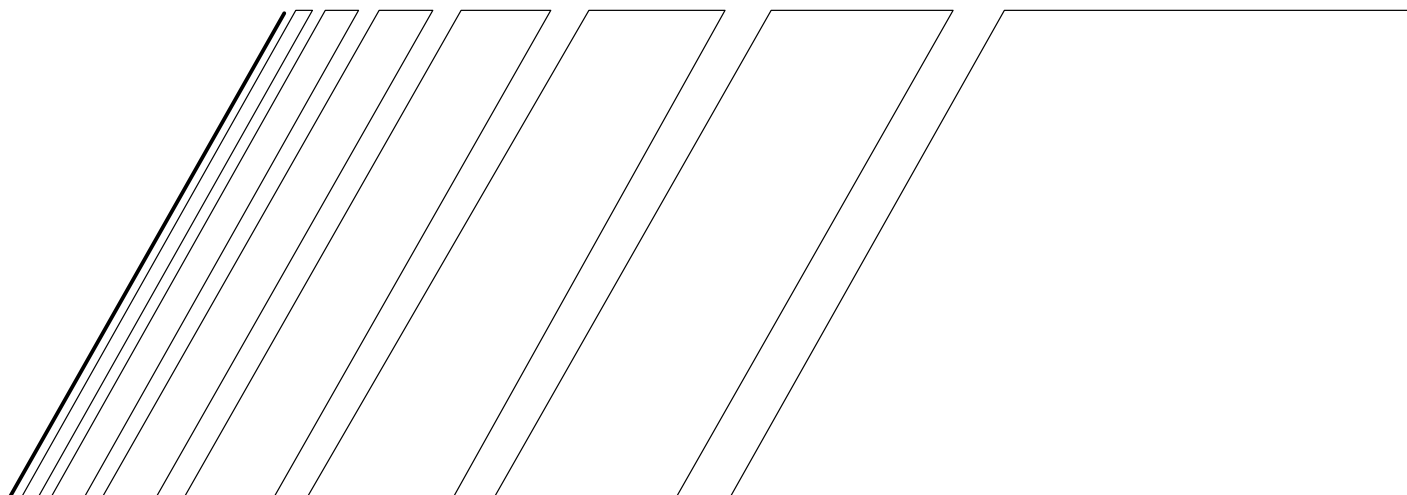

# **SETUP MANUAL**

# **SYSDRIVE 3G3JV**

**Compact Simplified Inverters**

---

Thank you for choosing this SYSDRIVE 3G3JV-series product. Proper use and handling of the product will ensure proper product performance, will lengthen product life, and may prevent possible accidents.

Please read this manual thoroughly and handle and operate the product with care.

---

1. To ensure safe and proper use of the OMRON Inverters, please read this SETUP MANUAL and the USER'S MANUAL (Cat. No. I528-E1) to gain sufficient knowledge of the devices, safety information, and precautions before actual use.
2. The products are illustrated without covers and shieldings for closer look in this SETUP MANUAL and the USER'S MANUAL. For actual use of the products, make sure to use the covers and shieldings as specified.
3. This SETUP MANUAL and other related user's manuals are to be delivered to the actual end users of the products.
4. Please keep this manual close at hand for future reference.
5. If the product has been left unused for a long time, please inquire at our sales representative.

## **NOTICE**

1. This manual describes the functions of the product and relations with other products. You should assume that anything not described in this manual is not possible.
2. Although care has been given in documenting the product, please contact your OMRON representative if you have any suggestions on improving this manual.
3. The product contains potentially dangerous parts under the cover. Do not attempt to open the cover under any circumstances. Doing so may result in injury or death and may damage the product. Never attempt to repair or disassemble the product.
4. We recommend that you add the following precautions to any instruction manuals you prepare for the system into which the product is being installed.
  - Precautions on the dangers of high-voltage equipment.
  - Precautions on touching the terminals of the product even after power has been turned OFF. (These terminals are live even with the power turned OFF.)
5. Specifications and functions may be changed without notice in order to improve product performance.

## **Items to Check Before Unpacking**

Check the following items before removing the product from the package:

- Has the correct product been delivered (i.e., the correct model number and specifications)?
- Has the product been damaged in shipping?
- Are any screws or bolts loose?

## **Notice:**

OMRON products are manufactured for use according to proper procedures by a qualified operator and only for the purposes described in this manual.

The following conventions are used to indicate and classify precautions in this manual. Always heed the information provided with them. Failure to heed precautions can result in injury to people or damage to property.

 **DANGER** Indicates an imminently hazardous situation which, if not avoided, will result in death or serious injury. Additionally, there may be severe property damage.

 **WARNING** Indicates a potentially hazardous situation which, if not avoided, could result in death or serious injury. Additionally, there may be severe property damage.

 **Caution** Indicates a potentially hazardous situation which, if not avoided, may result in minor or moderate injury, or property damage.

## **OMRON Product References**

All OMRON products are capitalized in this manual. The word “Unit” is also capitalized when it refers to an OMRON product, regardless of whether or not it appears in the proper name of the product.

The abbreviation “Ch,” which appears in some displays and on some OMRON products, often means “word” and is abbreviated “Wd” in documentation in this sense.

The abbreviation “PC” means Programmable Controller and is not used as an abbreviation for anything else.

## **Visual Aids**

The following headings appear in the left column of the manual to help you locate different types of information.

**Note** Indicates information of particular interest for efficient and convenient operation of the product.

## **© OMRON, 2005**

All rights reserved. No part of this publication may be reproduced, stored in a retrieval system, or transmitted, in any form, or by any means, mechanical, electronic, photocopying, recording, or otherwise, without the prior written permission of OMRON.

No patent liability is assumed with respect to the use of the information contained herein. Moreover, because OMRON is constantly striving to improve its high-quality products, the information contained in this manual is subject to change without notice. Every precaution has been taken in the preparation of this manual. Nevertheless, OMRON assumes no responsibility for errors or omissions. Neither is any liability assumed for damages resulting from the use of the information contained in this publication.

## ***Read and Understand this Manual***

Please read and understand this manual before using the product. Please consult your OMRON representative if you have any questions or comments.

## ***Warranty and Limitations of Liability***

### ***WARRANTY***

OMRON's exclusive warranty is that the products are free from defects in materials and workmanship for a period of one year (or other period if specified) from date of sale by OMRON.

OMRON MAKES NO WARRANTY OR REPRESENTATION, EXPRESS OR IMPLIED, REGARDING NON-INFRINGEMENT, MERCHANTABILITY, OR FITNESS FOR PARTICULAR PURPOSE OF THE PRODUCTS. ANY BUYER OR USER ACKNOWLEDGES THAT THE BUYER OR USER ALONE HAS DETERMINED THAT THE PRODUCTS WILL SUITABLY MEET THE REQUIREMENTS OF THEIR INTENDED USE. OMRON DISCLAIMS ALL OTHER WARRANTIES, EXPRESS OR IMPLIED.

### ***LIMITATIONS OF LIABILITY***

OMRON SHALL NOT BE RESPONSIBLE FOR SPECIAL, INDIRECT, OR CONSEQUENTIAL DAMAGES, LOSS OF PROFITS OR COMMERCIAL LOSS IN ANY WAY CONNECTED WITH THE PRODUCTS, WHETHER SUCH CLAIM IS BASED ON CONTRACT, WARRANTY, NEGLIGENCE, OR STRICT LIABILITY.

In no event shall the responsibility of OMRON for any act exceed the individual price of the product on which liability is asserted.

IN NO EVENT SHALL OMRON BE RESPONSIBLE FOR WARRANTY, REPAIR, OR OTHER CLAIMS REGARDING THE PRODUCTS UNLESS OMRON'S ANALYSIS CONFIRMS THAT THE PRODUCTS WERE PROPERLY HANDLED, STORED, INSTALLED, AND MAINTAINED AND NOT SUBJECT TO CONTAMINATION, ABUSE, MISUSE, OR INAPPROPRIATE MODIFICATION OR REPAIR.

## ***Application Considerations***

### ***SUITABILITY FOR USE***

OMRON shall not be responsible for conformity with any standards, codes, or regulations that apply to the combination of products in the customer's application or use of the products.

At the customer's request, OMRON will provide applicable third party certification documents identifying ratings and limitations of use that apply to the products. This information by itself is not sufficient for a complete determination of the suitability of the products in combination with the end product, machine, system, or other application or use.

The following are some examples of applications for which particular attention must be given. This is not intended to be an exhaustive list of all possible uses of the products, nor is it intended to imply that the uses listed may be suitable for the products:

- Outdoor use, uses involving potential chemical contamination or electrical interference, or conditions or uses not described in this manual.
- Nuclear energy control systems, combustion systems, railroad systems, aviation systems, medical equipment, amusement machines, vehicles, safety equipment, and installations subject to separate industry or government regulations.
- Systems, machines, and equipment that could present a risk to life or property.

Please know and observe all prohibitions of use applicable to the products.

**NEVER USE THE PRODUCTS FOR AN APPLICATION INVOLVING SERIOUS RISK TO LIFE OR PROPERTY WITHOUT ENSURING THAT THE SYSTEM AS A WHOLE HAS BEEN DESIGNED TO ADDRESS THE RISKS, AND THAT THE OMRON PRODUCTS ARE PROPERLY RATED AND INSTALLED FOR THE INTENDED USE WITHIN THE OVERALL EQUIPMENT OR SYSTEM.**

### ***PROGRAMMABLE PRODUCTS***

OMRON shall not be responsible for the user's programming of a programmable product, or any consequence thereof.

## **Disclaimers**

### ***CHANGE IN SPECIFICATIONS***

Product specifications and accessories may be changed at any time based on improvements and other reasons.

It is our practice to change model numbers when published ratings or features are changed, or when significant construction changes are made. However, some specifications of the products may be changed without any notice. When in doubt, special model numbers may be assigned to fix or establish key specifications for your application on your request. Please consult with your OMRON representative at any time to confirm actual specifications of purchased products.

### ***DIMENSIONS AND WEIGHTS***

Dimensions and weights are nominal and are not to be used for manufacturing purposes, even when tolerances are shown.

### ***PERFORMANCE DATA***

Performance data given in this manual is provided as a guide for the user in determining suitability and does not constitute a warranty. It may represent the result of OMRON's test conditions, and the users must correlate it to actual application requirements. Actual performance is subject to the OMRON Warranty and Limitations of Liability.

### ***ERRORS AND OMISSIONS***









The information in this manual has been carefully checked and is believed to be accurate; however, no responsibility is assumed for clerical, typographical, or proofreading errors, or omissions.

## General Precautions



Observe the following precautions when using the SYSDRIVE Inverters and peripheral devices.

This manual may include illustrations of the product with protective covers removed in order to describe the components of the product in detail. Make sure that these protective covers are on the product before use.





Consult your OMRON representative when using the product after a long period of storage.

-  **WARNING** Do not touch the inside of the Inverter. Doing so may result in electrical shock.
-  **WARNING** Operation, maintenance, or inspection must be performed after turning OFF the power supply, confirming that the CHARGE indicator (or status indicators) are OFF, and after waiting for the time specified on the front cover. Not doing so may result in electrical shock.
-  **WARNING** Do not damage, pull on, apply stress to, place heavy objects on, or pinch the cables. Doing so may result in electrical shock.
-  **WARNING** Do not touch the rotating parts of the motor under operation. Doing so may result in injury.
-  **WARNING** Do not modify the product. Doing so may result in injury or damage to the product.
-  **Caution** Do not store, install, or operate the product in the following places. Doing so may result in electrical shock, fire or damage to the product.
  - Locations subject to direct sunlight.
  - Locations subject to temperatures or humidity outside the range specified in the specifications.
  - Locations subject to condensation as the result of severe changes in temperature.
  - Locations subject to corrosive or flammable gases.
  - Locations subject to exposure to combustibles.
  - Locations subject to dust (especially iron dust) or salts.
  - Locations subject to exposure to water, oil, or chemicals.
  - Locations subject to shock or vibration.
-  **Caution** Do not touch the Inverter radiator, regenerative resistor, or Servomotor while the power is being supplied or soon after the power is turned OFF. Doing so may result in a skin burn due to the hot surface.
-  **Caution** Do not conduct a dielectric strength test on any part of the Inverter. Doing so may result in damage to the product or malfunction.
-  **Caution** Take appropriate and sufficient countermeasures when installing systems in the following locations. Not doing so may result in equipment damage.
  - Locations subject to static electricity or other forms of noise.
  - Locations subject to strong electromagnetic fields and magnetic fields.
  - Locations subject to possible exposure to radioactivity.
  - Locations close to power supplies.





## ***Transportation Precautions***

-  **Caution** Do not hold by front cover or panel, instead, hold by the radiation fin (heat sink) while transporting the product. Doing so may result in injury.
-  **Caution** Do not pull on the cables. Doing so may result in damage to the product or malfunction.
-  **Caution** Use the eye-bolts only for transporting the Inverter. Using them for transporting the machinery may result in injury or malfunction.







## ***Installation Precautions***

-  **WARNING** Provide an appropriate stopping device on the machine side to secure safety. (A holding brake is not a stopping device for securing safety.) Not doing so may result in injury.
-  **WARNING** Provide an external emergency stopping device that allows an instantaneous stop of operation and power interruption. Not doing so may result in injury.
-  **Caution** Be sure to install the product in the correct direction and provide specified clearances between the Inverter and control panel or with other devices. Not doing so may result in fire or malfunction.
-  **Caution** Do not allow foreign objects to enter inside the product. Doing so may result in fire or malfunction.
-  **Caution** Do not apply any strong impact. Doing so may result in damage to the product or malfunction.







## ***Wiring Precautions***







-  **WARNING** Wiring must be performed only after confirming that the power supply has been turned OFF. Not doing so may result in electrical shock.
-  **WARNING** Wiring must be performed by authorized personnel. Not doing so may result in electrical shock or fire.
-  **WARNING** Be sure to confirm operation only after wiring the emergency stop circuit. Not doing so may result in injury.
-  **WARNING** Always connect the ground terminals to a ground of 100  $\Omega$  or less. Not connecting to a proper ground may result in electrical shock.









-  **Caution** Install external breakers and take other safety measures against short-circuiting in external wiring. Not doing so may result in fire.
-  **Caution** Confirm that the rated input voltage of the Inverter is the same as the AC power supply voltage. An incorrect power supply may result in fire, injury, or malfunction.
-  **Caution** Connect the Braking Resistor and Braking Resistor Unit as specified in the manual. Not doing so may result in fire.
-  **Caution** Be sure to wire correctly and securely. Not doing so may result in injury or damage to the product.
-  **Caution** Be sure to firmly tighten the screws on the terminal block. Not doing so may result in fire, injury, or damage to the product.
-  **Caution** Do not connect an AC power to the U, V, or W output. Doing so may result in damage to the product or malfunction.
-  **Caution** Set the multi-function contact input parameter for NC contact terminals (e.g., 3-wire sequence) before wiring them. If the parameter's default setting is used, the motor may start running when the input terminal S2 is turned ON.

## ***Operation and Adjustment Precautions***

-  **WARNING** Turn ON the input power supply only after mounting the front cover, terminal covers, bottom cover, Operator, and optional items. Not doing so may result in electrical shock.
-  **WARNING** Do not remove the front cover, terminal covers, bottom cover, Operator, or optional items while the power is being supplied. Doing so may result in electrical shock or damage to the product.
-  **WARNING** Do not operate the Operator or switches with wet hands. Doing so may result in electrical shock.
-  **WARNING** Do not touch the inside of the Inverter. Doing so may result in electrical shock.
-  **WARNING** Do not come close to the machine when using the error retry function because the machine may abruptly start when stopped by an alarm. Doing so may result in injury.
-  **WARNING** Do not come close to the machine immediately after resetting momentary power interruption to avoid an unexpected restart (if operation is set to be continued in the processing selection function after momentary power interruption is reset). Doing so may result in injury.

-  **WARNING** Provide a separate emergency stop switch because the STOP Key on the Operator is valid only when function settings are performed. Not doing so may result in injury.
-  **WARNING** Be sure to confirm that the RUN signal is turned OFF before turning ON the power supply, resetting the alarm, or switching the LOCAL/REMOTE selector. Doing so while the RUN signal is turned ON may result in injury.
-  **Caution** Be sure to confirm permissible ranges of motors and machines before operation because the Inverter speed can be easily changed from low to high. Not doing so may result in damage to the product.
-  **Caution** Provide a separate holding brake when necessary. Not doing so may result in injury.
-  **Caution** Do not perform a signal check during operation. Doing so may result in injury or damage to the product.
-  **Caution** Do not carelessly change settings. Doing so may result in injury or damage to the product.

## ***Maintenance and Inspection Precautions***

-  **WARNING** Do not touch the Inverter terminals while the power is being supplied.
-  **WARNING** Maintenance or inspection must be performed only after turning OFF the power supply, confirming that the CHARGE indicator (or status indicators) is turned OFF, and after waiting for the time specified on the front cover. Not doing so may result in electrical shock.
-  **WARNING** Maintenance, inspection, or parts replacement must be performed by authorized personnel. Not doing so may result in electrical shock or injury.
-  **WARNING** Do not attempt to take the Unit apart or repair. Doing either of these may result in electrical shock or injury.
-  **Caution** Carefully handle the Inverter because it uses semiconductor elements. Careless handling may result in malfunction.
-  **Caution** Do not change wiring, disconnect connectors, the Operator, or optional items, or replace fans while power is being supplied. Doing so may result in injury, damage to the product, or malfunction.

## Warnings for UL/cUL Marking

- Do not connect or disconnect wiring, or perform signal checks while the power supply is turned ON.
- The Inverter internal capacitor is still charged even after the power supply is turned OFF. To prevent electrical shock, disconnect all power before servicing the Inverter. Then wait at least one minute after the power supply is disconnected and all indicators are OFF.
- Do not perform a withstand voltage test on any part of the Inverter. This electronic equipment uses semiconductors and is vulnerable to high voltage.
- Do not remove the Digital Operator or the blank cover unless the power supply is turned OFF. Never touch the printed control board (PCB) while the power supply is turned ON.
- The Inverter is not suitable for use on a circuit capable of delivering more than 5,000 RMS symmetrical amperes, 250 volts maximum (100-V-class Units).
- Take measures against overcurrent, overload, and overheating by using the Motor Protection Settings.

### CAUTION

Use 75°C copper wires or equivalent.  
Low voltage wires shall be wired with Class I Wiring.

## ■ Motor Protection Settings

### Rated Motor Current (n32)

- Set the rated motor current (n32) in order to prevent the motor from burning due to overloading.
- Check the rated current on the motor nameplate and set the parameter.
- This parameter is used for the electronic thermal function for motor overload detection (OL1). By setting the correct parameter, the overloaded motor will be protected from burning.

| n32                  | Rated Motor Current                                  |                        |       | Changes during operation | No           |
|----------------------|--|------------------------|-------|--------------------------|--------------|
| <b>Setting range</b> | 0.0% to 120% (A) of rated output current of Inverter | <b>Unit of setting</b> | 0.1 A | <b>Default setting</b>   | (see note 1) |

**Note 1.** The standard rated current of the maximum applicable motor is the default rated motor current.

**Note 2.** Motor overload detection (OL1) is disabled by setting the parameter to 0.0.

### Motor Protection Characteristics (n33 and n34)

- This parameters setting is for motor overload detection (OL1).

| n33                  | Motor Protection Characteristic Selection |                        |   | Changes during operation | No |
|----------------------|---|------------------------|---|--------------------------|----|
| <b>Setting range</b> | 0 to 2                                    | <b>Unit of setting</b> | 1 | <b>Default setting</b>   | 0  |

### ● Set Values

| Value | Description   |
|-------|---|
| 0     | Protection characteristics for general-purpose induction motors |
| 1     | Protection characteristics for Inverter-dedicated motors        |
| 2     | No protection   |

- This parameter is used to set the electric thermal characteristics of the motor to be connected.
- Set the parameter according to the motor.
- If a single Inverter is connected to more than one motor, set the parameter to 2 for no protection. The parameter is also disabled by setting n32 for rated motor current to 0.0. Provide thermal relays or other methods separately for each motor to protect equipment from overloads.

|                      |                              |                        |       |                                 |    |
|----------------------|------------------------------|------------------------|-------|---------------------------------|----|
| <b>n34</b>           | <b>Motor Protection Time</b> |                        |       | <b>Changes during operation</b> | No |
| <b>Setting range</b> | 1 to 60 (min)                | <b>Unit of setting</b> | 1 min | <b>Default setting</b>          | 8  |

### ● Set Values

- This parameter is used to set the electronic thermal protection constant of motor overload detection OL1.
- The default setting does not need any changes in normal operation.
- To set the parameter according to the characteristics of the motor, confirm the thermal time constant with the motor manufacturer and set the parameter with some margin. In other words, set the value a little shorter than the thermal time constant.
- To detect motor overloading more quickly, reduce the set value, provided that it does not cause any application problems.



# Table of Contents

---

## **Chapter 1. Design ..... 1-1**

|       |  |      |
|-------|--|------|
| 1-1   | Installation .....                     | 1-2  |
| 1-1-1 | Dimensions .....                       | 1-2  |
| 1-1-2 | Removing and Mounting the Covers ..... | 1-4  |
| 1-2   | Wiring .....                           | 1-6  |
| 1-2-1 | Terminal Block .....                   | 1-6  |
| 1-2-2 | Standard Connections .....             | 1-10 |
| 1-2-3 | Wiring around the Main Circuit .....   | 1-11 |
| 1-2-4 | Optional Accessories .....             | 1-12 |
| 1-3   | Specifications .....                   | 1-13 |

## **Chapter 2. Preparing for Operation and Monitoring ..... 2-1**

|       |   |      |
|-------|---|------|
| 2-1   | Nomenclature .....  | 2-2  |
| 2-2   | Outline of Operation .....                                | 2-4  |
| 2-3   | Copying and Verifying Parameters .....                    | 2-6  |
| 2-3-1 | Parameters Used to Copy and Verify Parameters .....       | 2-6  |
| 2-3-2 | Outline of Copying Parameters .....                       | 2-8  |
| 2-3-3 | Procedures .....  | 2-9  |
| 2-3-4 | Error Messages for Copying and Verifying Parameters ..... | 2-11 |

## **Chapter 3. List of Parameters ..... 3-1**

## **Chapter 4. Maintenance Operations ..... 4-1**

|       |   |      |
|-------|---|------|
| 4-1   | Protective and Diagnostic Functions ..... | 4-2  |
| 4-1-1 | Fault Detection (Fatal Error) .....       | 4-2  |
| 4-1-2 | Warning Detection (Nonfatal Error) .....  | 4-7  |
| 4-2   | Inspection and Maintenance .....          | 4-10 |

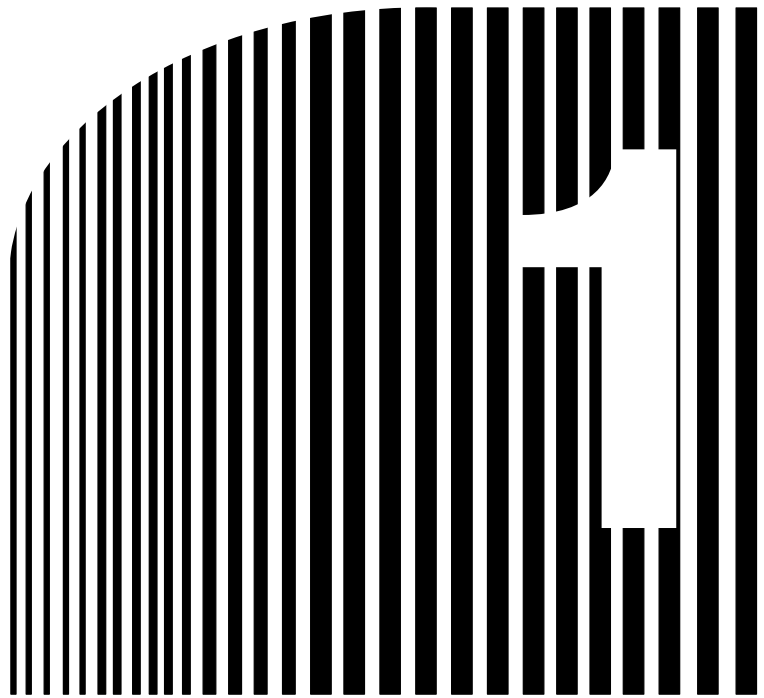

# Chapter 1

## • Design •

- 1-1 Installation
- 1-2 Wiring

## 1-1 Installation

### 1-1-1 Dimensions

● 3G3JV-A1001, -A1002 (0.1 to 0.2 kW) Single-phase 100-V AC Input

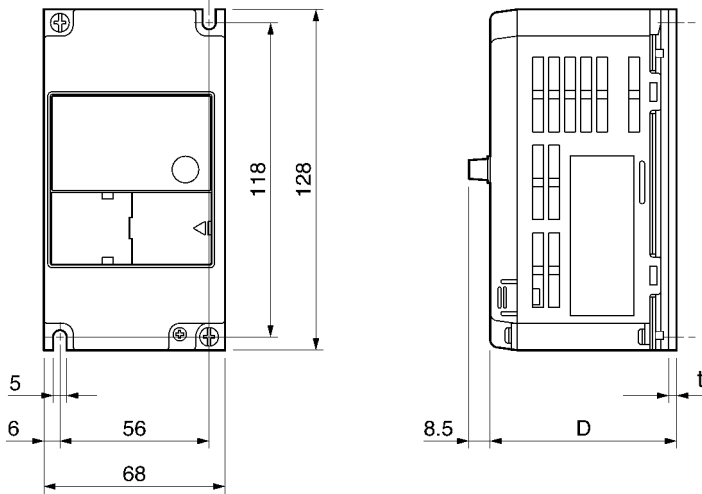

| Rated voltage         | Model 3G3JV- | Dimensions (mm) |   | Weight (kg) |
|-----------------------|--------------|-----------------|---|-------------|
|                       |              | D               | t |             |
| Single-phase 100 V AC | A1001        | 80              | 3 | Approx. 0.5 |
|                       | A1002        | 112             | 5 | Approx. 0.8 |

#### ■ Installation Direction and Dimensions

- Install the Inverter under the following conditions.

Ambient temperature for operation (panel-mounting):  $-10^{\circ}\text{C}$  to  $50^{\circ}\text{C}$

Humidity: 95% or less (no condensation)

- Install the Inverter in a clean location free from oil mist and dust. Alternatively, install it in a totally enclosed panel that is completely protected from floating dust.
- When installing or operating the Inverter, always take special care so that metal powder, oil, water, or other foreign matter does not get into the Inverter.
- Do not install the Inverter on inflammable material such as wood.

#### ■ Direction

- Install the Inverter on a vertical surface so that the characters on the nameplate are oriented upward.



## ■ Dimensions

- When installing the Inverter, always provide the following clearances to allow normal heat dissipation from the Inverter.

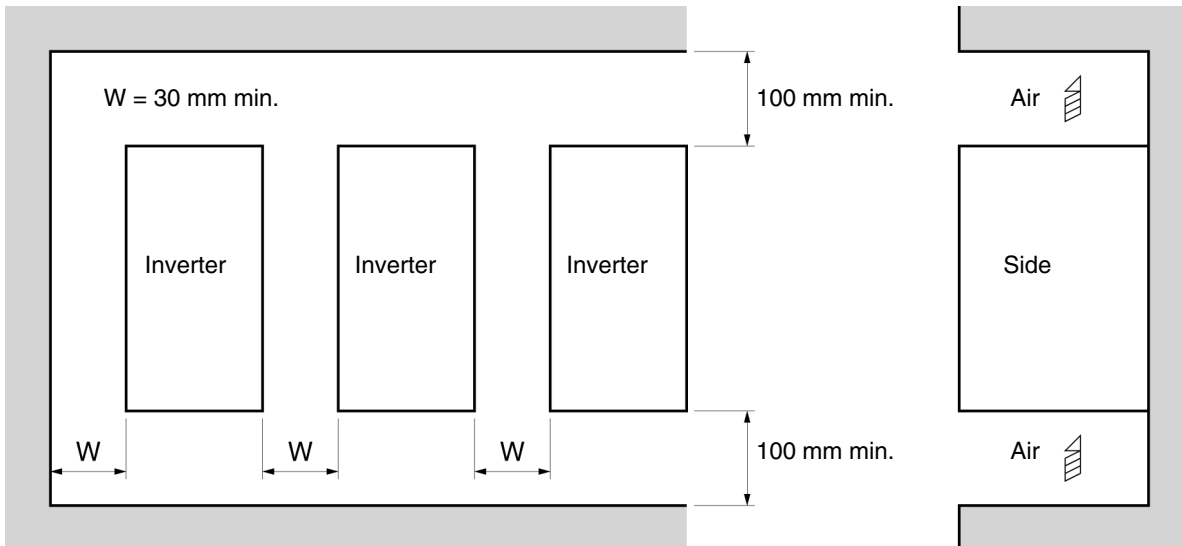

## ■ Ambient Temperature Control

- To enhance operation reliability, the Inverter should be installed in an environment free from extreme temperature changes.
- If the Inverter is installed in an enclosed environment such as a box, use a cooling fan or air conditioner to maintain the internal air temperature below  $50^{\circ}\text{C}$ .  
The life of the built-in electrolytic capacitors of the Inverter is prolonged by maintaining the internal air temperature as low as possible.
- The surface temperature of the Inverter may rise approximately  $30^{\circ}\text{C}$  higher than the ambient temperature. Be sure to keep away equipment and wires from the Inverter as far as possible if the equipment and wires are easily influenced by heat.

## ■ Protecting Inverter from Foreign Matter during Installation

- Place a cover over the Inverter during installation to shield it from metal power produced by drilling. Upon completion of installation, always remove the cover from the Inverter. Otherwise, ventilation will be affected, causing the Inverter to overheat.

## 1-1-2 Removing and Mounting the Covers

---

It is necessary to remove the front cover, optional cover, top protection cover, and the bottom protection cover from the Inverter to wire the terminal block.

Follow the instructions below to remove the covers from the Inverter.

To mount the covers, take the opposite steps.

---

### ■ Removing the Front Cover

- Loosen the front cover mounting screws with a screwdriver.
- Press the left and right sides of the front cover in the arrow 1 directions and lift the bottom of the cover in the arrow 2 direction to remove the front cover as shown in the following illustration.

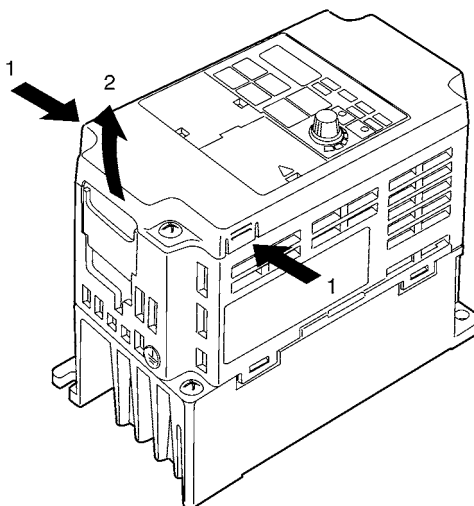

### ■ Removing the Top and Bottom Protection Covers and Optional Cover

#### ● Removing the Top and Bottom Protection Covers

- After removing the front cover, pull the top and bottom protection covers in the arrow 1 directions.

● **Removing the Optional Cover**

- After removing the front cover, lift the optional cover in the arrow 2 direction based on position A as a fulcrum.

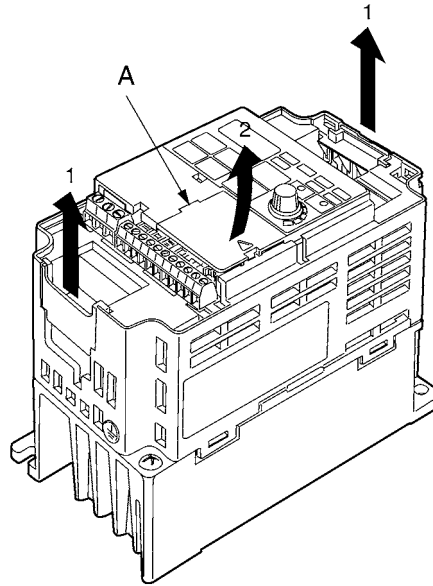

**Note** The front cover functions as a terminal cover. The Digital Operator cannot be removed.

## 1-2 Wiring

### 1-2-1 Terminal Block

Before wiring the terminal block, be sure to remove the front cover, top protection cover, and the bottom protection cover.

#### ■ Position of Terminal Block

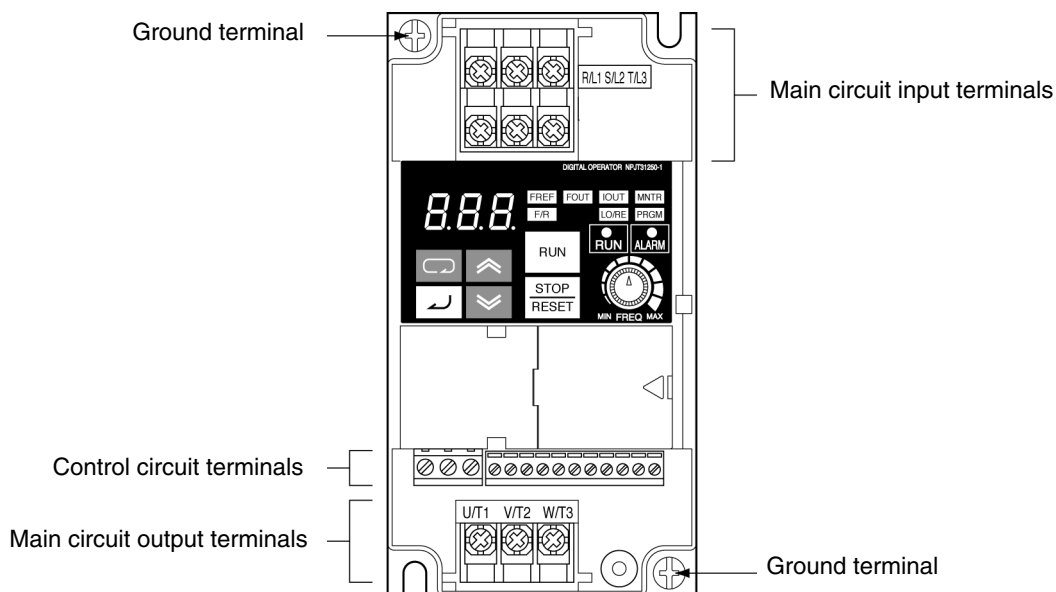

#### ■ Arrangement of Control Circuit Terminals

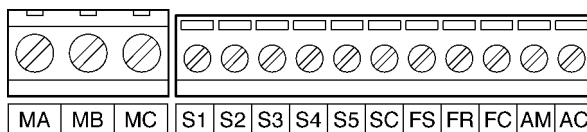

■ Arrangement of Main Circuit Terminals

- 3G3JV-A1001, -A1002

Main Circuit Input Terminals  
(Upper Side)

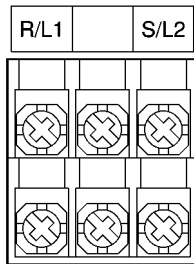

Main Circuit Output Terminals  
(Lower Side)

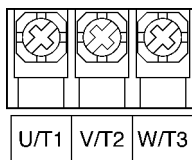

■ Main Circuit Terminals

| Symbol | Name                         | Description  |
|--------|------------------------------|--|
| R/L1   | Power supply input terminals | 3G3JV-A1□: Single-phase 100 to 115 V AC<br><b>Note</b> Connect single-phase input to terminals R/L1 and S/L2.  |
| S/L2   |                              |  |
| U/T1   | Motor output terminals       | 3-phase power supply output for driving motors.<br>3G3JV-A1□: 3-phase 200 to 230 V AC  |
| V/T2   |                              |  |
| W/T3   |                              |  |
|        | Ground terminal              | Be sure to ground the terminal under the following conditions.<br>3G3JV-A1□: Ground at a resistance of 100 Ω or less, and connect to the power supply's neutral phase to conform to EC Directives.<br><b>Note</b> Be sure to connect the ground terminal directly to the motor frame ground. |

**Note** The maximum output voltage corresponds to the power supply input voltage of the Inverter.

■ Control Circuit Terminals

| Symbol |    | Name  | Function   | Signal level   |
|--------|----|---|--|--|
| Input  | S1 | Forward/Stop                                    | Forward at ON. Stops at OFF.                         | Photocoupler<br>8 mA at 24 V DC<br><br><b>Note</b> NPN is the default setting for these terminals. Wire them by providing a common ground. No external power supply is required. To provide an external power supply and wire the terminals through a common positive line, however, set the SW7 to PNP and make sure that the power supply is at 24 V DC $\pm 10\%$ . |
|        | S2 | Multi-function input 1 (S2)                     | Set by parameter n36 (Reverse/Stop)                  |  |
|        | S3 | Multi-function input 2 (S3)                     | Set by parameter n37 (Fault reset)                   |  |
|        | S4 | Multi-function input 3 (S4)                     | Set by parameter n38 (External fault: Normally open) |  |
|        | S5 | Multi-function input 4 (S5)                     | Set by parameter n39 (Multi-step reference 1)        |  |
|        | SC | Sequence input common                           | Common for S1 through S5                             |  |
|        | FS | Frequency reference power supply                | DC power supply for frequency reference use          | 20 mA at 12 V DC   |
|        | FR | Frequency reference input                       | Input terminal for frequency reference use           | 0 to 10 V DC (input impedance: 20 k $\Omega$ )   |
|        | FC | Frequency reference common                      | Common for frequency reference use                   |  |
| Output | MA | Multi-function contact output (Normally open)   | Set by parameter n40 (during running)                | Relay output<br>1 A max. at 30 V DC<br>1 A max. at 250 V AC  |
|        | MB | Multi-function contact output (Normally closed) |  |  |
|        | MC | Multi-function contact output common            | Common for MA and MB use                             |  |
|        | AM | Analog monitor output                           | Set by parameter n44 (Output frequency)              | 2 mA max. at 0 to 10 V DC  |
|        | AC | Analog monitor output common                    | Common for AM use                                    |  |

**Note 1.** Depending on the parameter settings, various functions can be selected for multi-function inputs and multi-function contacts outputs.

**Note 2.** Functions in parentheses are default settings.

■ Selecting Input Method

- Switches SW7 and SW8, both of which are located above the control circuit terminals, are used for input method selection.

Remove the front cover and optional cover to use these switches.

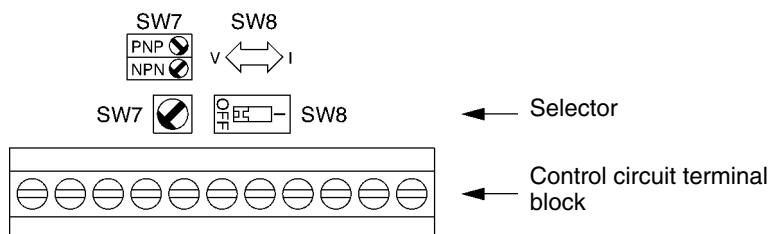

● **Selecting Sequence Input Method**

- By using SW7, NPN or PNP input can be selected as shown below.

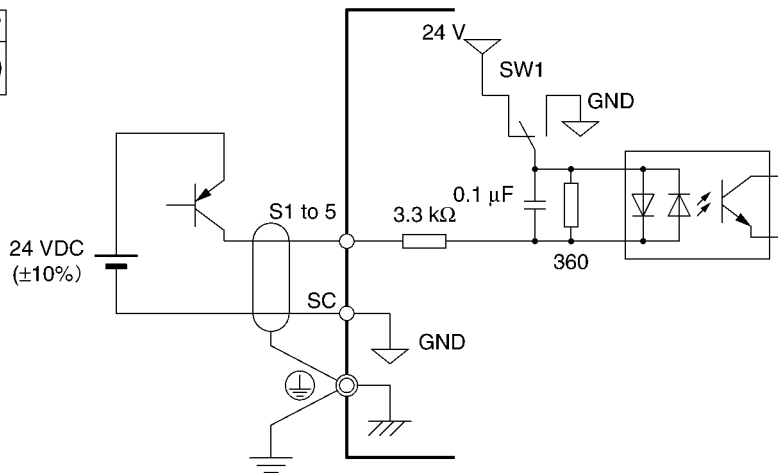
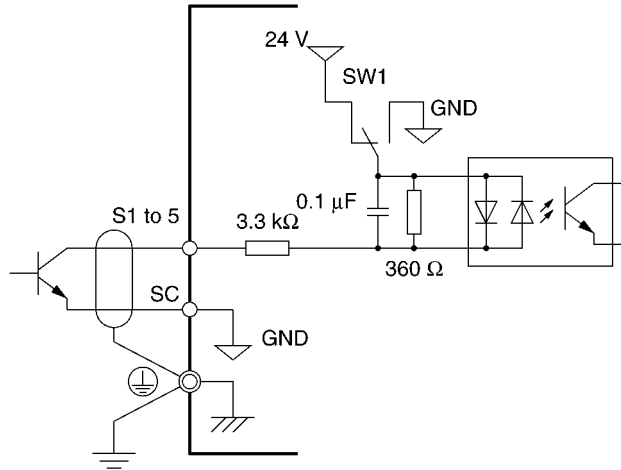

● **Selecting Frequency Reference Input Method**

| Frequency reference input method | SW8 setting | Frequency reference selection (parameter n03) |
|----------------------------------|-------------|---|
| Voltage input                    | V (OFF)     | Set value 2                                   |
| Current input                    | I (ON)      | Set value 3 or 4                              |

### 1-2-2 Standard Connections

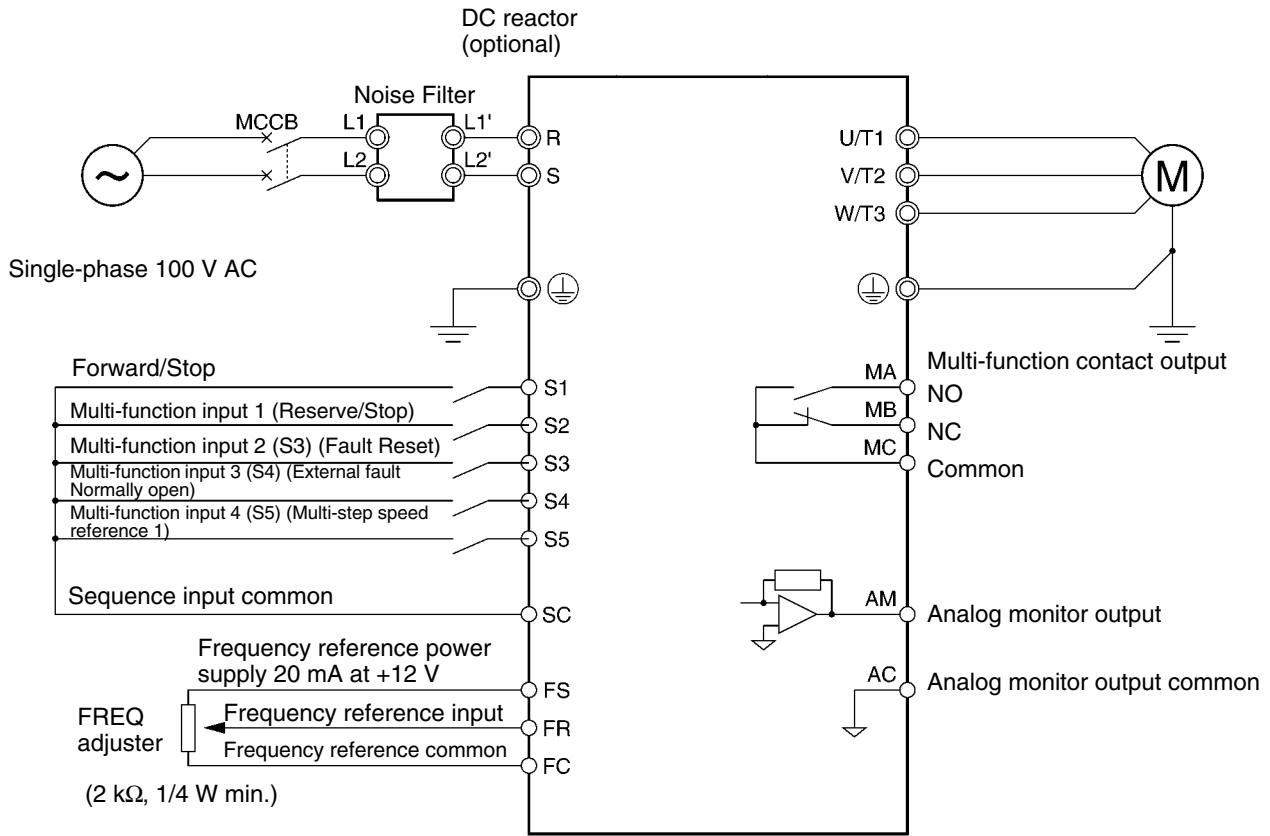

- Note 1.** The braking resistor cannot be connected because no braking transistor is incorporated.
- Note 2.** A DC Reactor can be connected in series between the R input and L1 terminal or between the S input and L2 terminal to use it as an AC reactor.

#### • DC Reactor Wiring Example

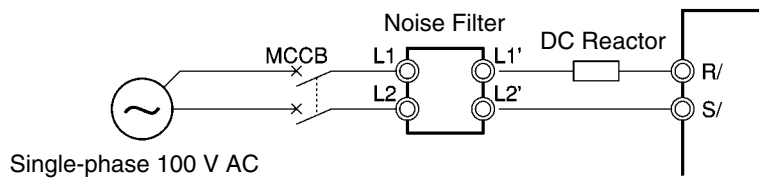

#### Applicable Noise Filters

| Inverter    | Applicable Filter                               | Specifications                 |
|-------------|---|--------------------------------|
| 3G3JV-A1001 | 3G3JV-PRS1010J<br>(for either 0.1 kW or 0.2 kW) | 10 A at 250 V AC, single-phase |
| 3G3JV-A1002 |   |                                |

#### Applicable DC Reactors

| Inverter    | Applicable Reactor  | Specifications |
|-------------|---------------------|----------------|
| 3G3JV-A1001 | 3G3HV-PUZDAB5.4A8MH | 5.4 A, 8 mH    |
| 3G3JV-A1002 | 3G3HV-PUZDAB18A3MH  | 18 A, 3 mH     |



● Example of 3-wire Sequence Connections

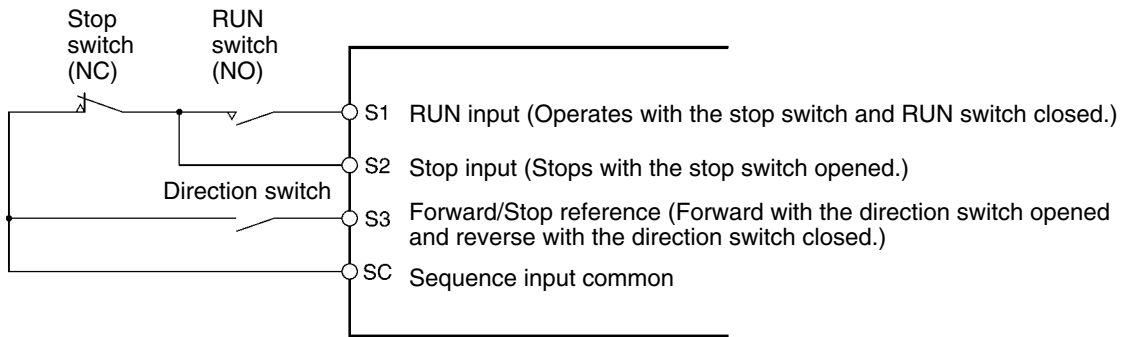

**Note** Set parameter n37 for 3-wire sequence input.

### 1-2-3 Wiring around the Main Circuit

■ Wire Size, Terminal Screw, Screw Tightening Torque, and Molded-case Circuit Breaker Capacities

- For the main circuit and ground, always use 600-V polyvinyl chloride (PVC) cables.
- If any cable is long and may cause voltage drops, increase the wire size according to the cable length.

● Single-phase 100-V AC Model

| Model 3G3JV- | Terminal symbol              | Terminal screw | Screw tightening torque (N•m) | Wire size (mm <sup>2</sup> ) | Recommended wire size (mm <sup>2</sup> ) |
|--------------|------------------------------|----------------|-------------------------------|------------------------------|--|
| A1001        | R/L1, S/L2, U/T1, V/T2, W/T3 | M3.5           | 0.8 to 1.0                    | 0.75 to 2                    | 2  |
|              |                              |                |                               |                              |  |
| A1002        | R/L1, S/L2, U/T1, V/T2, W/T3 | M3.5           | 0.8 to 1.0                    | 0.75 to 2                    | 2  |
|              |                              |                |                               |                              |  |

■ Wiring

Control Circuit

| Terminal symbol                  | Terminal screw | Screw tightening torque N•m (lb•in) | Wire size mm <sup>2</sup> (AWG)  | Recommended wire size mm <sup>2</sup> (AWG) |
|----------------------------------|----------------|-------------------------------------|--|---|
| MA, MB, MC                       | M3             | 0.5 to 0.6 (4.4 to 5.3)             | Stranded wire:<br>0.5 to 1.25 (20 to 16)<br>Single wire:<br>0.5 to 1.25 (20 to 16) | 0.75 (18)                                   |
| S1 to S5, SC, FS, FR, FC, AM, AC | M2             | 0.22 to 0.25 (2 to 2.2)             | Stranded wire:<br>0.5 to 0.75 (20 to 18)<br>Single wire:<br>0.5 to 1.25 (20 to 16) | 0.75 (18)                                   |

## 1-2-4 Optional Accessories

| Option                     | Specifications               |           | Model                |
|----------------------------|------------------------------|-----------|----------------------|
| EMC-compliant Noise Filter | For A1001                    |           | 3G3JV-PRS1010J       |
|                            | For A1002                    |           |                      |
| DC Reactor                 | For A1001                    |           | 3G3HV-PUZDAB5, 4A8MH |
|                            | For A1002                    |           | 3G3HV-PUZDAB18A3MH   |
| DIN Track Mounting Bracket | ---                          |           | 3G3IV-PEZZ08122A     |
| Adapter Panel              | Standard installation        |           | 3G3JV-PSI232J        |
|                            | Removable                    |           | 3G3JV-PSI232JC       |
| Operator Cable             | 1 m                          |           | 3G3IV-PCN126         |
|                            | 3 m                          |           | 3G3IV-PCN326         |
| Digital Operator           | Without adjuster (with case) |           | 3G3IV-PJVOP146       |
|                            | With adjuster                | Main Unit | 3G3IV-PJVOP140       |
|                            |                              | Case      | 3G3IV-PEZZ08386      |

**1-3 Specifications**

|                             | 100-V AC Models                                   | 3G3JV-A1001   | 3G3JV-A1002 |
|-----------------------------|---|---|-------------|
| Power supply                | Rated voltage and power supply                    | Single-phase 100 to 115 V AC at 50/60 Hz  |             |
|                             | Allowable voltage fluctuation                     | -15 to 10%  |             |
|                             | Allowable frequency fluctuation                   | ±5%   |             |
|                             | Input current (for rated output) (A)              | 3.2   | 6.2         |
| Heating radiation (W)       |   | 14.6  | 21.1        |
| Weight (kg)                 |   | 0.5   | 0.8         |
| Cooling method              |   | Natural cooling   |             |
| Maximum motor capacity (kW) |   | 0.1   | 0.2         |
| Output specifications       | Rated output capacity (kVA)                       | 0.3   | 0.6         |
|                             | Rated output current (A)                          | 0.8   | 1.6         |
|                             | Rated output voltage (V)                          | Three-phase 200 to 230 V (Handles twice the input voltage.)                                       |             |
|                             | Maximum output frequency                          | 400 Hz (Set in a parameter.)  |             |
| Control characteristics     | Power supply harmonics countermeasures            | DC Reactor (optional) can be connected.   |             |
|                             | Control method                                    | Sine wave PWM (V/f control)   |             |
|                             | Carrier frequency                                 | 2.5 to 10.0 kHz (Switched in steps.)  |             |
|                             | Frequency control range                           | 0.1 to 400 Hz   |             |
|                             | Frequency precision (temperature characteristics) | Digital reference: ±0.01% (-10 to 50°C)   |             |
|                             |   | Analog reference: ±0.5% (25°C ±10°C)  |             |
|                             | Frequency setting resolution                      | Digital reference: 0.1 Hz (less than 100 Hz), 1 Hz (100 Hz or greater)                            |             |
|                             |   | Analog reference: 0.06 Hz/60 Hz (equivalent to 1/1000)  |             |
|                             | Output frequency resolution                       | 0.01 Hz (data processing resolution)  |             |
|                             | Overload capacity                                 | 150% of rated output current for 1 min  |             |
|                             | External frequency set signal                     | Switchable: 0 to 10 V DC (20 kΩ), 4 to 20 mA (250 Ω), 0 to 20 mA (250 Ω), or frequency adjustment |             |
|                             | Acceleration/deceleration times                   | 0.0 to 999 s (Acceleration and deceleration times set separately: Switches between 2 settings.)   |             |
|                             | Braking torque                                    | Approx. 20%<br>Note: A Braking Resistor or Braking Resistor Unit cannot be connected.             |             |
|                             | Voltage/frequency characteristics                 | User-set V/f pattern  |             |

|                      | 100-V AC Models                                       | 3G3JV-A1001   | 3G3JV-A1002 |
|----------------------|---|---|-------------|
| Protective functions | Motor protection                                      | Protection by electronic thermal  |             |
|                      | Instantaneous overcurrent protection                  | Stops at approx. 250% of rated output current.  |             |
|                      | Overload protection                                   | Stops in 1 min at approximately 150% of rated output current.   |             |
|                      | Overvoltage protection                                | Stops when main-circuit DC voltage is approximately 410 V.  |             |
|                      | Undervoltage protection                               | Stops when main-circuit DC voltage is approximately 160 V.  |             |
|                      | Momentary power interruption compensation (selection) | None (Stops at 15 ms or longer.)<br>Select between continuing operation if power is restored within approx. 0.5 s or continuing operation regardless of length of interruption. |             |
|                      | Radiation fin overheated                              | Detected at 110°C ±10°C   |             |
|                      | Grounding protection                                  | Rated output current level protection   |             |
|                      | Charge indicator                                      | CHARGE indicator lights until the main circuit DC voltage reaches 50 V or less.   |             |
| Environment          | Location  | Indoors (with no corrosive gas, dust, etc.)   |             |
|                      | Ambient operating temperature                         | -10 to 50°C   |             |
|                      | Ambient operating humidity                            | 95% max. (with no condensation)   |             |
|                      | Storage temperature                                   | -20 to 60°C   |             |
|                      | Altitude  | 1,000 m max.  |             |
|                      | Insulation resistance                                 | 5 MΩ min. (Do not carry out any insulation resistance or withstand voltage tests.)  |             |
|                      | Vibration resistance                                  | 9.8 m/s <sup>2</sup> max. between 10 and 20 Hz, 2.0 m/s <sup>2</sup> max. between 20 and 50 Hz  |             |
| Degree of protection | Mounted in a panel (equivalent to IP20)               |   |             |

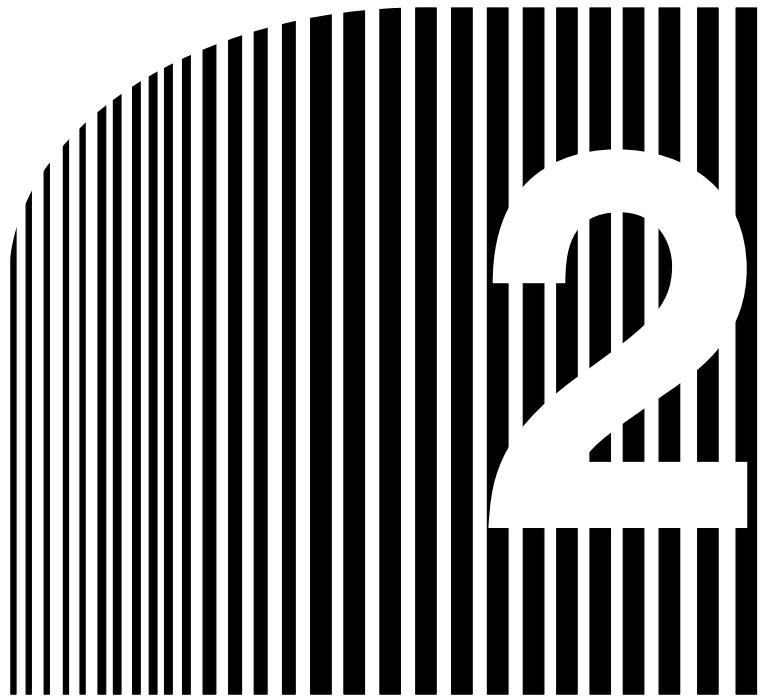

## Chapter 2



- **Preparing for Operation and Monitoring** •

- 2-1 Nomenclature
- 2-2 Outline of Operation
- 2-3 Copying and Verifying Parameters

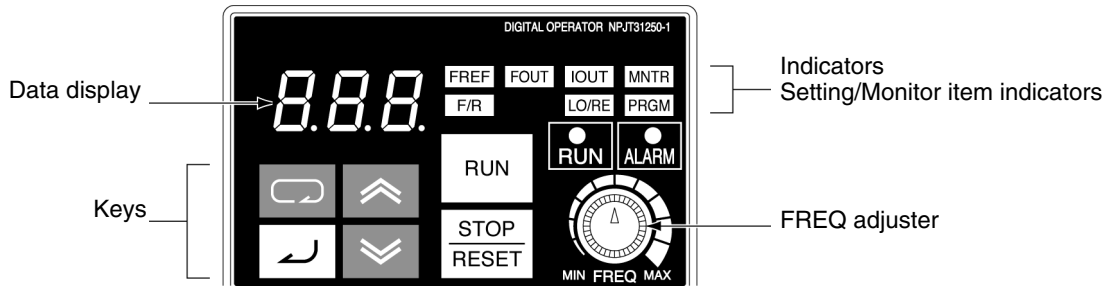
2-1 Nomenclature



| Appearance | Name            | Function  |
|------------|-----------------|---|
|            | Data display    | Displays relevant data items, such as frequency reference, output frequency, and parameter set values.  |
|            | FREQ adjuster   | Sets the frequency reference within a range between 0 Hz and the maximum frequency.   |
|            | FREF indicator  | The frequency reference can be monitored or set while this indicator is lit.  |
|            | FOUT indicator  | The output frequency of the Inverter can be monitored while this indicator is lit.  |
|            | IOUT indicator  | The output current of the Inverter can be monitored while this indicator is lit.  |
|            | MNTR indicator  | The values set in U01 through U10 are monitored while this indicator is lit.  |
|            | F/R indicator   | The direction of rotation can be selected while this indicator is lit, when operating the Inverter with the RUN Key.  |
|            | LO/RE indicator | The operation of the Inverter through the Digital Operator or according to the parameters set is selectable while this indicator is lit.<br><br><b>Note</b> This status of this indicator can be only monitored while the Inverter is in operation. Any RUN command input is ignored while this indicator is lit. |
|            | PRGM indicator  | The parameters in n01 through n79 can be set or monitored while this indicator is lit.<br><br><b>Note</b> While the Inverter is in operation, the parameters can be only monitored and only some parameters can be changed. The RUN command input is ignored while this indicator is lit.                         |
|            | Mode Key        | Switches the setting and monitor item indicators in sequence.<br><br>Parameter setting being made is canceled if this key is pressed before entering the setting.   |
|            | Increment Key   | Increases multi-function monitor numbers, parameter numbers, and parameter set values.  |
|            | Decrement Key   | Decreases multi-function monitor numbers, parameter numbers, and parameter set values.  |

| <b>Appearance</b>   | <b>Name</b>    | <b>Function</b>   |
|---|----------------|---|
|  | Enter Key      | Enters multi-function monitor numbers, parameter numbers, and internal data values after they are set or changed.                 |
|  | RUN Key        | Starts the Inverter running when the 3G3FV is in operation with the Digital Operator.   |
|  | STOP/RESET Key | Stops the Inverter unless n06 is set to disable the STOP Key. Functions as a Reset Key when an Inverter error occurs. (See note.) |

**Note** For safety's reasons, the reset will not work while a RUN command (forward or reverse) is in effect. Wait until the RUN command is OFF before resetting the Inverter.

## 2-2 Outline of Operation

### ■ Selecting Indicators

Whenever the Mode Key is pressed, an indicator is lit in sequence beginning with the FREF indicator. The data display indicates the item corresponding to the indicator selected.

The FOUT or IOUT indicator will be lit by turning the Inverter on again if the Inverter is turned off while the FOUT or IOUT indicator is lit. The FREF indicator will be lit by turning the Inverter on again if the Inverter is turned off while an indicator other than the FOUT or IOUT indicator is lit.

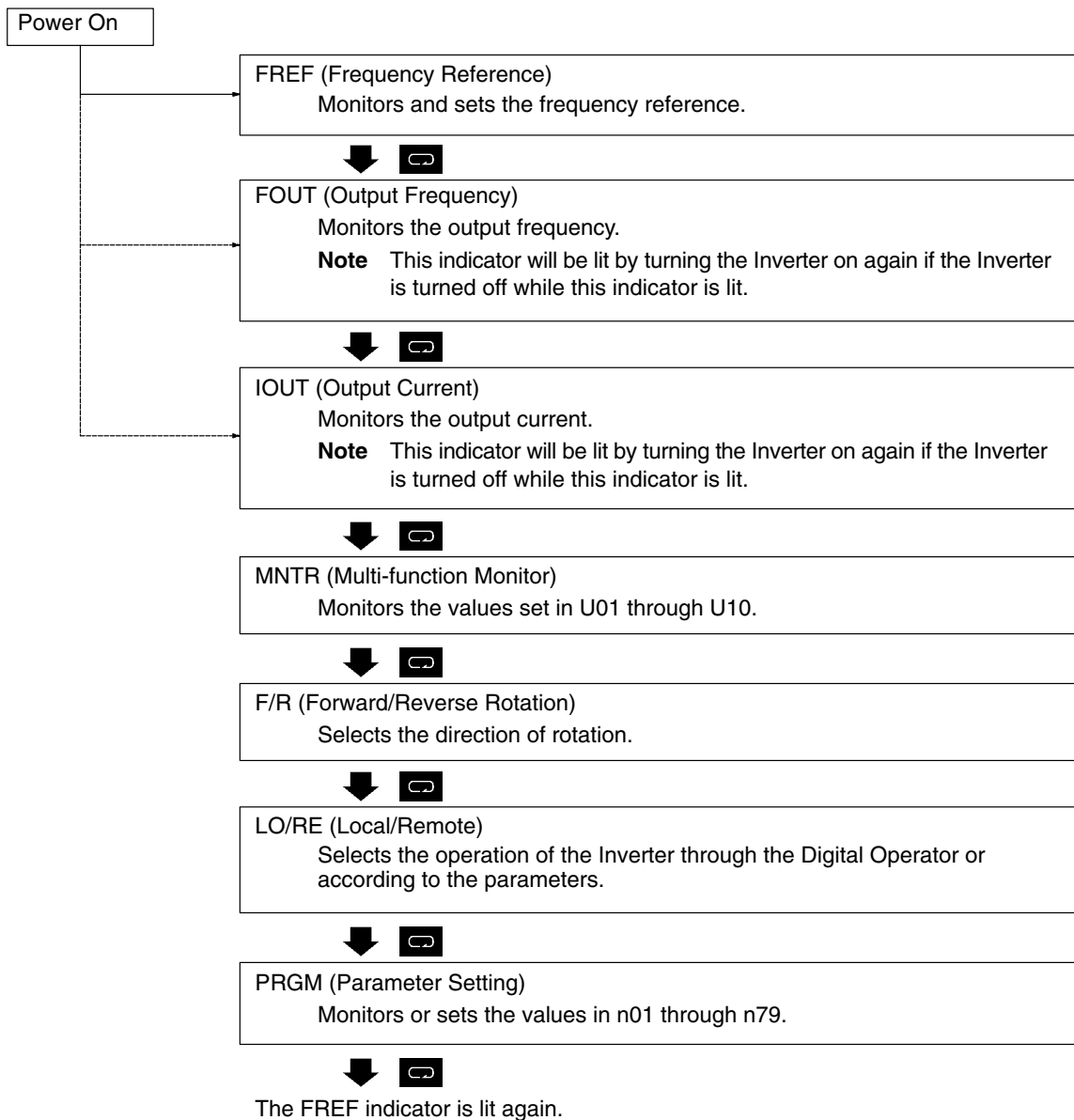



■ Example of Multi-function Display

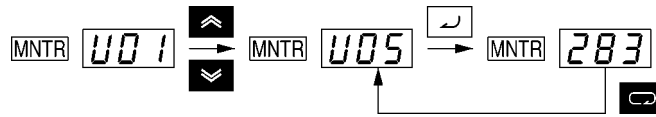

| Key sequence | Indicator | Display | Explanation  |
|--------------|-----------|---------|--|
|              | FREF      | 6.0     | Power On   |
|              | MNTR      | U01     | Press the Mode Key repeatedly until the MNTR indicator is lit.<br>U01 will be displayed. |
|              | MNTR      | U05     | Use the Increment or Decrement Key to select the monitor item to be displayed.           |
|              | MNTR      | 283     | Press the Enter Key so that the data of the selected monitor item will be displayed.     |
|              | MNTR      | U05     | The monitor number display will appear again by pressing the Mode Key.                   |

● Status Monitor

| Item | Display                     | Display unit | Function  |
|------|-----------------------------|--------------|---|
| U01  | Frequency reference         | Hz           | Monitors the frequency reference. (Same as FREF)  |
| U02  | Output frequency            | Hz           | Monitors the output frequency. (Same as FOUT)   |
| U03  | Output current              | A            | Monitors the output current. (Same as IOUT)   |
| U04  | Output voltage              | V            | Monitors the internal output voltage reference value of the Inverter.   |
| U05  | DC bus voltage              | V            | Monitors the DC voltage of the internal main circuit of the Inverter.   |
| U06  | Input terminal status       | ---          | Shows the ON/OFF status of inputs.<br>  |
| U07  | Output terminal status      | ---          | Shows the ON/OFF status of outputs.<br>   |
| U09  | Error log (most recent one) | ---          | Displays the latest error.<br>  |
| U10  | Software No.                | ---          | OMRON use only.   |
| U15  | Receive data error          | ---          | The cause of the receive data error during MEMOBUS communications can be checked. (Same as the contents of communications register number 003DM.) |

## 2-3 Copying and Verifying Parameters

The 3G3IV-PJVOP140 and 3G3IV-PJOP146 Digital Operators contain an EEPROM. All Inverter parameter settings, the Inverter capacity, and the software number are recorded in this EEPROM. The EEPROM can be used to copy parameter settings to other Inverters.

Parameter settings can be copied between Inverters with the same power supply specifications, but some of the parameter settings are not copied.

### 2-3-1 Parameters Used to Copy and Verify Parameters

- The following parameters are used to read, copy (write), and verify parameter settings.

| Parameter No. (Register No. (Hex)) | Name                               | Description  | Setting range | Setting unit | Default setting | Changes during operation |
|------------------------------------|------------------------------------|--|---------------|--------------|-----------------|--------------------------|
| n76 (014C)                         | Parameter copy and verify function | Selects the function for copying parameters.<br>rdy: Ready to accept the next command.<br>rED: Reads the Inverter parameters.<br>Cpy: Copies the parameter to the Inverter.<br>vFY: Verifies the Inverter parameters.<br>vA: Checks the Inverter capacity display.<br>Sno: Checks the software number. | rdy to Sno    | ---          | rdy             | No                       |
| n77 (014D)                         | Parameter read prohibit selection  | Selects the copy-prohibit function.<br>Use this parameter to protect the data in the EEPROM of the Digital Operator.<br>0: Read prohibited for Inverter parameters. (Data cannot be written to EEPROM.)<br>1: Read possible for Inverter parameters. (Data can be written to EEPROM.)                  | 0, 1          | ---          | 0               | No                       |

■ Display Transitions

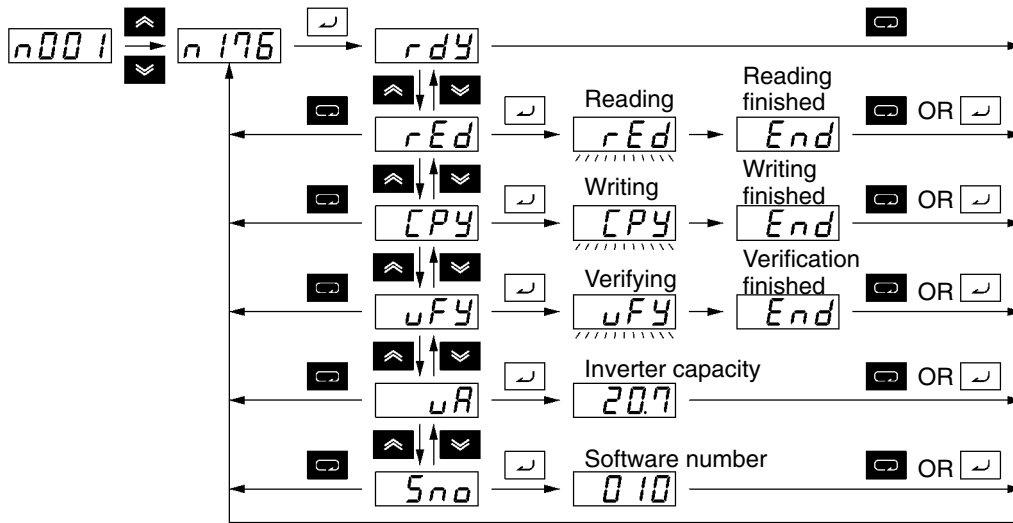

**Note** The following display is an example of the capacity displayed. The values in parentheses indicate the capacities for European motors.

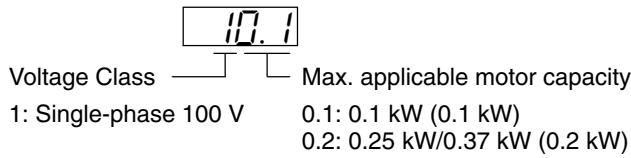

**Note** The values in parentheses indicate Japanese motor capacities.

### 2-3-2 Outline of Copying Parameters

- (1) Check setting of n01  
 0: Writing from Digital Operator prohibited.  
 1: Parameters can be changed (default setting).
- (2) Clear prohibition of reading the copy function: n77  
 This function protects parameters stored in the Digital Operator.  
 0: Reading copy function (rEd) prohibited (default setting).  
 1: Reading copy function (rEd) enabled.
- (3) Perform the read operation for the copy function: n76  
 Read (rEd) the current parameter settings from the Inverter to the EEPROM in the Digital Operator.
- (4) Disconnect the Digital Operator and connect it to a different Inverter. Always turn OFF the power supply before connecting or disconnecting the Digital Operator to protect against electric shock and product failure.
- (5) Perform the write operation for the copy function: n76  
 Write (CPy) the current parameter settings from the EEPROM in the Digital Operator to the Inverter.
- (6) Perform the verify operation for the copy function: n76  
 Verify (vFy) the current parameter settings between the EEPROM in the Digital Operator and the Inverter.

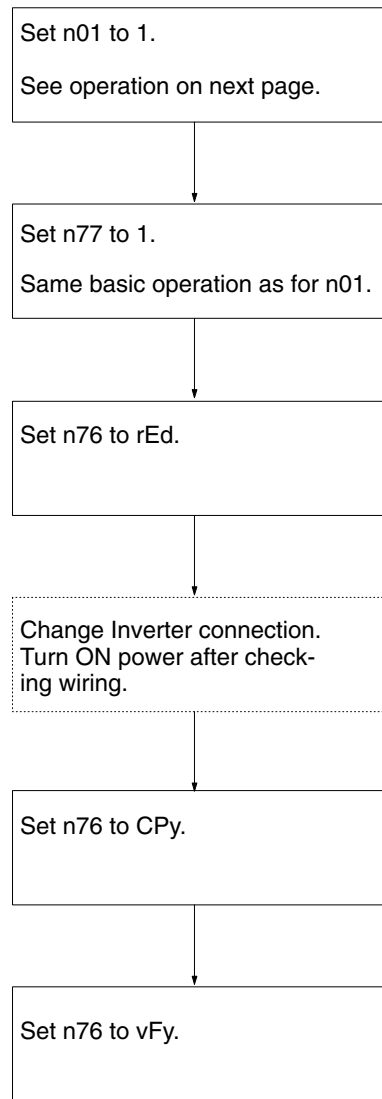

#### ■ Parameters That Cannot Be Copied

1. Copying is not possible between Inverters with different power supply specifications (e.g., from a 100-V Inverter to a 400-V Inverter).
2. The recorded hold output frequency and the following parameters cannot be copied:
  - n76: Parameter copy and verify function
  - n77: Parameter read prohibit selection
  - n78: Error log
  - n79: Software number
3. The following parameters cannot be copied if the Inverters have different capacities.
  - n09 to n15: V/f settings
  - n32: Rated motor current
  - n46: Carrier frequency selection





n64: Motor rated slip  
 n65: Motor no-load current

### 2-3-3 Procedures

#### Changing Parameters

The setting of n01 is changed so that n76 and n77 can be displayed.

● **Setting n01 (Parameter Write-prohibit Selection/Parameter Initialization Parameter)**











| Key  | Indicator | Display | Description  |
|--|-----------|---------|--|
| ---  | FREF      | 0.00    | (Display after the power supply is turned ON.)   |
|   | PRGM      | n01     | Press the Mode Key until the PRGM indicator lights. Confirm that n01 is displayed on the data display. |
|   | PRGM      | 0       | Press the Enter Key. The setting of the specified parameter number will be displayed.                  |
|   | PRGM      | 1       | Press the Increment Key until 4 is displayed. (The display will flash.)                                |
|  | PRGM      | 1       | Press the Enter Key to confirm the setting. (The display will stop flashing.)                          |
| After about 1 s  | PRGM      | n01     | The display of the parameter number will return in about 1 s.  |

**Example of Copy Function**

■ **Verifying Parameters (vFy)**

- The Parameter Copy and Verify Function (n76) can be set to “vFy” to compare the parameter settings in the Digital Operator with those in the Inverter.

● **Verifying Parameters**

| Key  | Indicator | Display | Description  |
|--|-----------|---------|--|
| ---  | FREF      | 0.00    | (Display after the power supply is turned ON.)   |
|   | PRGM      | n01     | Press the Mode Key until the PRGM indicator lights. Confirm that n01 is displayed on the data display.             |
|   | PRGM      | n76     | Press the Increment/Decrement Key until “n76” is displayed.  |
|   | PRGM      | rdy     | Press the Enter Key. “rdy” will be displayed.  |
|   | PRGM      | vFy     | Press the Increment Key until “vFy” is displayed   |
|   | PRGM      | vFy     | Press the Enter Key. The parameter settings will be compared and the display will flash.                           |
|  | PRGM      | n11     | The parameter number of any parameter that has different settings will be displayed.                               |
|   | PRGM      | 600     | Press the Enter Key. The setting of the parameter in the Inverter will be displayed (flashing) first.              |
|   | PRGM      | 500     | Press the Enter Key again. The setting of the parameter in the Digital Operator will be displayed (flashing) next. |
|   | PRGM      | vFy     | Press the Increment Key. The comparison will be continued.   |
| (After comparison is finished.)  | PRGM      | End     | “End” will be displayed when the comparison has been finished.   |
|  or  | PRGM      | n76     | Press the Mode Key or Enter Key. The display of the parameter number will return.                                  |

### 2-3-4 Error Messages for Copying and Verifying Parameters

The errors that can be displayed when reading, writing, or verifying parameter settings are described in the following table along with corrective actions. All of these error displays will flash on the display.

| Display     | Name                        | Description   | Corrective action  |
|-------------|-----------------------------|---|--|
| <i>P-rE</i> | Protect error               | An attempt was made to read parameter settings when the Parameter Read Prohibit Selection parameter (n77) was set to 0 (prohibiting reading). | Confirm that it is necessary to read the parameter settings. If it is, change the Parameter Read Prohibit Selection parameter (n77) to 1 (enabling reading). |
| <i>r-dE</i> | Read error                  | The parameter settings could not be read normally or a low main circuit voltage was detected while reading parameter settings.                | Check the main circuit voltage and then attempt reading again.   |
| <i>∑SE</i>  | Checksum error              | A checksum error occurred for the parameters recorded in the Digital Operator.  | Read the parameter settings again to record them in the Digital Parameter.   |
| <i>n-dt</i> | No data error               | No parameters are recorded in the Digital Operator.   | Read the parameter settings to record them in the Digital Parameter.   |
| <i>EPE</i>  | Copy source error           | Copying or verifying parameter settings was attempted between Inverters with different voltage classes.                                       | Check the voltage classes. (They must both be the same to copy parameter settings.)  |
| <i>∑YE</i>  | Voltage error while copying | A low main circuit voltage was detected while reading parameter settings.   | Check the main circuit voltage and then attempt copying again.   |
| <i>urE</i>  | Capacity error              | Verification was attempted between Inverters of different capacities.   | Press the Enter Key to continue the comparison.<br>Press the STOP/RESET Key to cancel the comparison.  |
| <i>∑FE</i>  | Communications error        | A communications error occurred between the Inverter and Digital Operator.  | Check the connection between the Inverter and the Digital Operator. Correct any problems and then repeat the operation.                                      |

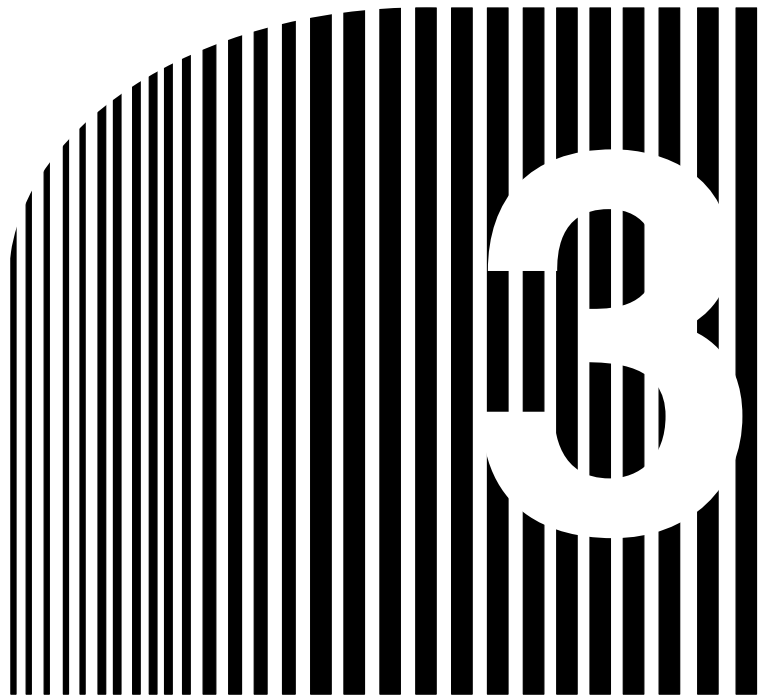

## Chapter 3

- **List of Parameters** •



| Parameter No. (Register No. (Hex)) | Name  | Description   | Setting range | Default setting | Changes during operation | Memo |
|------------------------------------|---|---|---------------|-----------------|--------------------------|------|
| n01<br>(0101)                      | Parameter write-prohibit selection/parameter initialization | Used to prohibit parameters to be written, sets parameters, or change the monitor range of parameters.<br>Used to initialize parameters to default values.<br>0: Sets or monitors parameter n01. Parameters n02 through n79 can be monitored only.<br>1: Sets or monitors parameters n01 through n79.<br>6: Clears the error log.<br>8: Initializes parameters to default values in 2-wire sequence.<br>9: Initializes parameters to default values in 3-wire sequence. | 0, 1, 6, 8, 9 | 1               | No                       |      |
| n02<br>(0102)                      | Operation command selection                                 | Used to select the input method for the RUN and STOP commands in remote mode.<br>0: The RUN and STOP/RESET Keys on the Digital Operator are enabled.<br>1: Multi-function inputs through the control circuit terminals in 2- or 3-wire sequence.<br>2: Operation commands via RS-422A/485 communications are enabled.<br><b>Note</b> The RUN command only through key sequences on the Digital Operator is acceptable in local mode.                                    | 0 to 2        | 0               | No                       |      |
| n03<br>(0103)                      | Frequency reference selection                               | Used to set the input method for the frequency reference in remote mode.<br>0: Digital Operator<br>1: Frequency reference 1 (n21)<br>2: Frequency reference control circuit terminal (0 to 10 V)<br>3: Frequency reference control circuit terminal (4 to 20 mA)<br>4: Frequency reference control circuit terminal (0 to 20 mA)<br>6: Frequency reference via RS-422A/485 communications   | 0 to 4, 6     | 0               | No                       |      |

| Parameter No. (Register No. (Hex)) | Name                                | Description  | Setting range | Default setting | Changes during operation | Memo |
|------------------------------------|-------------------------------------|--|---------------|-----------------|--------------------------|------|
| n04<br>(0104)                      | Interruption mode selection         | Used to set the stopping method for use when the STOP command is input.<br>0: Decelerates to stop in preset time.<br>1: Coasts to stop (with output shut off by the STOP command)  | 0, 1          | 0               | No                       |      |
| n05<br>(0105)                      | Reverse rotation-prohibit selection | Used to select the operation with the reverse command input.<br>0: Reverse enabled.<br>1: Reverse disabled.  | 0, 1          | 0               | No                       |      |
| n06<br>(0106)                      | STOP/RESET Key function selection   | Used to select the stop method in remote mode with n02 for operation mode selection set to 1.<br>0: STOP/RESET Key of the Digital Operator enabled.<br>1: STOP/RESET Key of the Digital Operator enabled only when the Digital Operator is selected for the RUN command. | 0, 1          | 0               | No                       |      |
| n07<br>(0107)                      | Frequency selection in local mode   | Used to set the input method for the frequency reference in local mode.<br>0: The FREQ adjuster of the Digital Operator enabled.<br>1: Key sequences on the Digital Operator enabled.  | 0, 1          | 0               | No                       |      |
| n08<br>(0108)                      | Key sequential frequency setting    | Used to enable the Enter Key for setting the frequency reference with the Increment and Decrement Keys.<br>0: The value is entered with the Enter Key pressed.<br>1: The value is enabled when the value is input.   | 0, 1          | 0               | No                       |      |
| n09<br>(0109)                      | Maximum frequency (FMAX)            | Used to set the V/f pattern as the basic characteristic of the Inverter with output voltage per frequency set.   | 50.0 to 400   | 60.0            | No                       |      |

| Parameter No. (Register No. (Hex)) | Name                                    | Description  | Setting range        | Default setting | Changes during operation | Memo |
|------------------------------------|---|--|----------------------|-----------------|--------------------------|------|
| n10 (010A)                         | Maximum voltage (VMAX)                  | <p><b>Note</b> Set the parameters so that the following condition will be satisfied.<br/> <math>n14 \leq n12 &lt; n11 \leq n09</math></p> <p><b>Note</b> The value set in n13 will be ignored if parameters n14 and n12 are the same in value.</p>   | 1 to 255             | 200             | No                       |      |
| n11 (010B)                         | Maximum voltage frequency (FA)          |  | 0.2 to 400           | 60.0            | No                       |      |
| n12 (010C)                         | Middle output frequency (FB)            |  | 0.1 to 399           | 1.5             | No                       |      |
| n13 (010D)                         | Middle output frequency voltage (VC)    |  | 1 to 255             | 12              | No                       |      |
| n14 (010E)                         | Minimum output frequency (FMIN)         |  | 0.1 to 10.0          | 1.5             | No                       |      |
| n15 (010F)                         | Minimum output frequency voltage (VMIN) |  | 1 to 50 (see note 2) | 12.0            | No                       |      |
| n16 (0110)                         | Acceleration time 1                     | Acceleration time: The time required to go from 0% to 100% of the maximum frequency.   | 0.0 to 999           | 10.0            | Yes                      |      |
| n17 (0111)                         | Deceleration time 1                     | Deceleration time: The time required to go from 100% to 0% of the maximum frequency.<br><b>Note</b> The actual acceleration or deceleration time is obtained from the following formula.<br>Acceleration/Deceleration time = (Acceleration/Deceleration time set value) × (Frequency reference value) ÷ (Max. frequency) |                      | 10.0            | Yes                      |      |
| n18 (0112)                         | Acceleration time 2                     |  |                      | 10.0            | Yes                      |      |
| n19 (0113)                         | Deceleration time 2                     |  |                      | 10.0            | Yes                      |      |

| Parameter No. (Register No. (Hex)) | Name   | Description   | Setting range | Default setting | Changes during operation | Memo |
|------------------------------------|--|---|---------------|-----------------|--------------------------|------|
| n20<br>(0114)                      | S-shape acceleration/deceleration characteristic | <p>Used to set S-shape acceleration/deceleration characteristics.</p> <p>0: No S-shape acceleration/deceleration (trapezoidal acceleration/deceleration)</p> <p>1: S-shape acceleration/deceleration characteristic time 0.2 s</p> <p>2: S-shape acceleration/deceleration characteristic time 0.5 s</p> <p>3: S-shape acceleration/deceleration characteristic time 1.0 s</p> <p><b>Note</b> When the S-shape acceleration/deceleration characteristic time is set, the acceleration and deceleration times will be lengthened according to the S-shape at the beginning and end of acceleration/deceleration.</p> | 0 to 3        | 0               | No                       |      |

| Parameter No. (Register No. (Hex)) | Name                      | Description   | Setting range         | Default setting   | Changes during operation | Memo |
|------------------------------------|---------------------------|---|-----------------------|---|--------------------------|------|
| n21 (0115)                         | Frequency reference 1     | <p>Used to set internal frequency references.</p> <p><b>Note</b> Frequency reference 1 is enabled in remote mode with n03 for frequency reference selection set to 1.</p> <p><b>Note</b> These frequency references are selected with multi-step speed references (multi-function input).</p> | 0.0 to max. frequency | 6.0   | Yes                      |      |
| n22 (0116)                         | Frequency reference 2     |   |                       | 0.0   | Yes                      |      |
| n23 (0117)                         | Frequency reference 3     |   |                       | 0.0   | Yes                      |      |
| n24 (0118)                         | Frequency reference 4     |   |                       | 0.0   | Yes                      |      |
| n25 (0119)                         | Frequency reference 5     |   |                       | 0.0   | Yes                      |      |
| n26 (011A)                         | Frequency reference 6     |   |                       | 0.0   | Yes                      |      |
| n27 (011B)                         | Frequency reference 7     |   |                       | 0.0   | Yes                      |      |
| n28 (011C)                         | Frequency reference 8     |   |                       | 0.0   | Yes                      |      |
| n29 (011D)                         | Inching frequency command |   |                       | <p>Used to set the inching frequency command.</p> <p><b>Note</b> The inching frequency command is selected with the inching command (multi-function input). The inching frequency command takes precedence over the multi-step speed reference.</p> | 6.0                      | Yes  |

| Parameter No. (Register No. (Hex)) | Name                             | Description   | Setting range  | Default setting           | Changes during operation | Memo |
|------------------------------------|----------------------------------|---|--|---------------------------|--------------------------|------|
| n30<br>(011E)                      | Frequency reference upper limit  | Used to set the upper and lower frequency reference limits in percentage based on the maximum frequency as 100%.<br><b>Note</b> If n31 is set to a value less than the minimum output frequency (n14), the Inverter will have no output when a frequency reference less than the minimum output frequency input is input.   | 0 to 110   | 100                       | No                       |      |
| n31<br>(011F)                      | Frequency reference lower limit  |   | 0 to 110   | 0                         | No                       |      |
| n32<br>(0120)                      | Rated motor current              | Used to set the rated motor current for motor overload detection (OL1) based on the rated motor current.<br><b>Note</b> Motor overload detection (OL1) is disabled by setting the parameter to 0.0.<br><b>Note</b> The rated motor current is default to the standard rated current of the maximum applicable motor.  | 0.0 to 120% of rated output current of the Inverter. | Varies with the capacity. | No                       |      |
| n33<br>(0121)                      | Motor protection characteristics | Used to set the motor overload detection (OL1) for the electronic thermal characteristics of the motor.<br>0: Protection characteristics for general-purpose induction motors<br>1: Protection characteristics for inverter-dedicated motors<br>2: No protection<br><b>Note</b> If a single Inverter is connected to more than one motor, set the parameter to 2 for no protection. The parameter is also disabled by setting n32 for rated motor to 0.0. | 0 to 2   | 0                         | No                       |      |

| Parameter No. (Register No. (Hex)) | Name                           | Description   | Setting range | Default setting | Changes during operation | Memo |
|------------------------------------|--------------------------------|---|---------------|-----------------|--------------------------|------|
| n34<br>(0122)                      | Motor protective time setting  | <p>Used to set the electric thermal characteristics of the motor to be connected in 1-minute increments.</p> <p><b>Note</b> The default setting does not require any changes in normal operation.</p> <p><b>Note</b> To set the parameter according to the characteristics of the motor, check with the motor manufacturer the thermal time constant and set the parameter with some margin. In other words, set the value slightly shorter than the thermal time constant.</p> <p><b>Note</b> To detect motor overloading quicker, reduce the set value, provided that it does not cause any application problems.</p> | 1 to 60       | 8               | No                       |      |
| n35<br>(0123)                      | Cooling fan operation function | <p>Used to operate the Cooling Fan of the Inverter while the Inverter is turned on or only while the Inverter is in operation.</p> <p>0: Rotates only while RUN command is input and for 1 minute after Inverter stops operating</p> <p>1: Rotates while Inverter is turned on</p> <p><b>Note</b> This parameter is available only if the Inverter incorporates a Cooling Fan.</p> <p><b>Note</b> If the operation frequency of the Inverter is low, the life of the fan can be prolonged by setting the parameter to 0.</p>  | 0, 1          | 0               | No                       |      |

| Parameter No. (Register No. (Hex)) | Name                                       | Description   |   |   | Setting range            | Default setting | Changes during operation | Memo |
|------------------------------------|--|---|---|---|--------------------------|-----------------|--------------------------|------|
| n36<br>(0124)                      | Multi-function input 1 (Input terminal S2) | Used to select the functions of multi-function input terminals S2 through S5. |   |   | 2 to 8, 10 to 22         | 2               | No                       |      |
|                                    |  | Set value   | Function                                  | Description   |                          |                 |                          |      |
| n37<br>(0125)                      | Multi-function input 2 (Input terminal S3) | 0   | Forward/Reverse rotation command          | 3-wire sequence (to be set in n37 only)<br>By setting n37 to 0, the set value in n36 is ignored and the following setting are forcibly made.<br>S1: RUN input (RUN when ON)<br>S2: STOP input (STOP when OFF)<br>S3: Forward/Reverse rotation command (OFF: Forward; ON: Reverse) | 0, 2 to 8, 10 to 22      | 5               | No                       |      |
| n38<br>(0126)                      | Multi-function input 3 (Input terminal S4) |   |   |   | 2 to 8, 10 to 22         | 3               | No                       |      |
| n39<br>(0127)                      | Multi-function input 4 (Input terminal S5) | 2   | Reverse/Stop                              | Reverse rotation command in 2-wire sequence (Reversed with the terminal turned ON)  | 2 to 8, 10 to 22, 34, 35 | 6               | No                       |      |
|                                    |  | 3   | External fault (NO)                       | ON: External fault (FP□ detection: □ is a terminal number)  |                          |                 |                          |      |
|                                    |  | 4   | External fault (NC)                       | OFF: External fault (EF□ detection: □ is a terminal number)   |                          |                 |                          |      |
|                                    |  | 5   | Fault reset                               | ON: Fault reset (disabled while RUN command is input)   |                          |                 |                          |      |
|                                    |  | 6   | Multi-step speed reference 1              | Signals to select frequency references 1 through 8.   |                          |                 |                          |      |
|                                    |  | 7   | Multi-step speed reference 2              |   |                          |                 |                          |      |
|                                    |  | 8   | Multi-step speed reference 3              |   |                          |                 |                          |      |
|                                    |  | 10  | Inching frequency command                 | ON: Inching frequency command (taking precedence over the multi-step speed reference)   |                          |                 |                          |      |
|                                    |  | 11  | Acceleration/Deceleration time changeover | ON: Acceleration time 2 and deceleration time 2 are selected.   |                          |                 |                          |      |



| Parameter No. (Register No. (Hex)) | Name                                       | Description |  |   | Setting range            | Default setting | Changes during operation | Memo |
|------------------------------------|--|-------------|--|---|--------------------------|-----------------|--------------------------|------|
| n39<br>(0127)                      | Multi-function input 4 (Input terminal S5) | 12          | External base block command (NO)                         | ON: Output shut off (while motor coasting to a stop and "bb" flashing)                            | 2 to 8, 10 to 22, 34, 35 | 6               | No                       |      |
|                                    |  | 13          | External base block command (NC)                         | OFF: Output shut off (with motor free running and "bb" flashing)                                  |                          |                 |                          |      |
|                                    |  | 14          | Search command (Searching starts from maximum frequency) | ON: Speed search (Searching starts from n09)  |                          |                 |                          |      |
|                                    |  | 15          | Search command (Searching starts from preset frequency)  | ON: Speed search  |                          |                 |                          |      |
|                                    |  | 16          | Acceleration/Deceleration-prohibit command               | ON: Acceleration/Deceleration is on hold (running at parameter frequency)                         |                          |                 |                          |      |
|                                    |  | 17          | Local or remote selection                                | ON: Local mode (operated with the Digital Operator)   |                          |                 |                          |      |
|                                    |  | 18          | Communications or remote selection                       | ON: RS-422A/485 communications input is enabled.<br>OFF: The settings of n02 and n03 are enabled. |                          |                 |                          |      |

| Parameter No. (Register No. (Hex)) | Name                                       | Description |                           | Setting range  | Default setting          | Changes during operation | Memo |
|------------------------------------|--|-------------|---------------------------|--|--------------------------|--------------------------|------|
| n39<br>(0127)                      | Multi-function input 4 (Input terminal S5) | 19          | Emergency stop fault (NO) | The Inverter stops according to the setting in n04 for interruption mode selection with the emergency stop input turned ON.  | 2 to 8, 10 to 22, 34, 35 | 6                        | No   |
|                                    |  | 20          | Emergency stop alarm (NO) | NO: Emergency stop with the contact closed.<br>NC: Emergency stop with the contact opened.   |                          |                          |      |
|                                    |  | 21          | Emergency stop fault (NC) | Fault: Fault output is ON and reset with RESET input. Alarm output is ON (no reset required).  |                          |                          |      |
|                                    |  | 22          | Emergency stop alarm (NC) | "STP" is displayed (lit with fault input ON and flashes with alarm input ON)   |                          |                          |      |
|                                    |  | 34          | Up or down command        | Up or down command (set in n39 only)<br><br>By setting n39 to 34, the set value in n38 is ignored and the following setting are forcibly made.<br>S4: Up command<br>S5: Down command |                          |                          |      |
|                                    |  | 35          | Self-diagnostic test      | ON: RS-422A/485 communications self-diagnostic test (set in n39 only)  |                          |                          |      |

| Parameter No. (Register No. (Hex)) | Name  | Description  | Setting range          | Default setting | Changes during operation | Memo |  |  |
|------------------------------------|---|--|------------------------|-----------------|--------------------------|------|--|--|
| n40<br>(0128)                      | Multi-function output (MA/MB and MC output terminals) | Used to select the functions of multi-function output terminals. | 0 to 7,<br>10 to<br>18 | 1               | No                       |      |  |  |
|                                    |   | <b>Set value</b>   |                        |                 |                          |      | <b>Function</b>                                | <b>Description</b>   |
|                                    |   | 0  |                        |                 |                          |      | Fault output                                   | ON: Fault output (with protective function working)  |
|                                    |   | 1  |                        |                 |                          |      | Operation in progress                          | ON: Operation in progress  |
|                                    |   | 2  |                        |                 |                          |      | Frequency detection                            | ON: Frequency detection (with frequency reference coinciding with output frequency)  |
|                                    |   | 3  |                        |                 |                          |      | Idling   | ON: Idling (at less than min. output frequency)  |
|                                    |   | 4  |                        |                 |                          |      | Frequency detection 1                          | ON: Output frequency $\geq$ frequency detection level (n58)  |
|                                    |   | 5  |                        |                 |                          |      | Frequency detection 2                          | ON: Output frequency $\leq$ frequency detection level (n58)  |
|                                    |   | 6  |                        |                 |                          |      | Overtorque being monitored (NO-contact output) | Output if any of the following parameter conditions is satisfied.<br>n59: Overtorque detection function selection<br>n60: Overtorque detection level |
|                                    |   | 7  |                        |                 |                          |      | Overtorque being monitored (NC-contact output) | n61: Overtorque detection time<br>NO contact: ON with overtorque being detected<br>NC contact: OFF with overtorque being detected                    |
|                                    |   | 8  |                        |                 |                          |      | Not used                                       | ---  |
|                                    |   | 9  |                        |                 |                          |      |  |  |
|                                    |   | 10   |                        |                 |                          |      | Alarm output                                   | ON: Alarm being detected (Nonfatal error being detected)   |
| 11                                 | Base block in progress                                | Base block in progress (in operation with output shutoff)        |                        |                 |                          |      |  |  |
| 12                                 | RUN mode  | ON: Local mode (with the Digital Operator)                       |                        |                 |                          |      |  |  |

| Parameter No. (Register No. (Hex)) | Name  | Description  |                                | Setting range  | Default setting  | Changes during operation | Memo |
|------------------------------------|---|--|--------------------------------|--|------------------|--------------------------|------|
| n40<br>(0128)                      | Multi-function output (MA/MB and MC output terminals) | 13   | Inverter ready                 | ON: Inverter ready to operate (with no fault detected)               | 0 to 7, 10 to 18 | 1                        | No   |
|                                    |   | 14   | Fault retry                    | ON: Fault retry  |                  |                          |      |
|                                    |   | 15   | UV in progress                 | ON: Undervoltage being monitored                                     |                  |                          |      |
|                                    |   | 16   | Rotating in reverse direction  | ON: Rotating in reverse direction                                    |                  |                          |      |
|                                    |   | 17   | Speed search in progress       | ON: Speed search in progress   |                  |                          |      |
|                                    |   | 18   | Data output via communications | The inverter operates multi-function output terminals independently. |                  |                          |      |
| n41<br>(0129)                      | Frequency reference gain                              | Used to the input characteristics of analog frequency references.<br>Gain: The frequency of maximum analog input (10 V or 20 mA) in percentage based on the maximum frequency as 100%.   |                                | 0 to 255   | 100              | Yes                      |      |
| n42<br>(012A)                      | Frequency reference bias                              | Bias: The frequency of minimum analog input (0 V or 0 or 4 mA) in percentage based on the maximum frequency as 100%.   |                                | -99 to 99  | 0                | Yes                      |      |
| n43<br>(012B)                      | Analog frequency reference time                       | Used to set the digital filter with a first-order lag for analog frequency references to be input.   |                                | 0.00 to 2.00   | 0.10             | No                       |      |
| n44<br>(012C)                      | Analog monitor output                                 | Used to set the output frequency or current as a monitored item.<br>0: Output frequency (10-V output at max. frequency with n45 set to 1.00).<br>1: Output current (10-V output with Inverter rated output current with n45 set to 1.00) |                                | 0, 1   | 0                | No                       |      |
| n45<br>(012D)                      | Analog monitor output gain                            | Used to set the output characteristics of analog monitor output.   |                                | 0.00 to 2.00   | 1.00             | Yes                      |      |

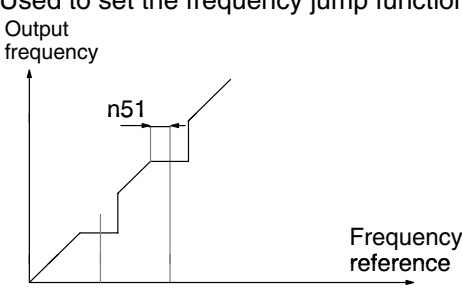
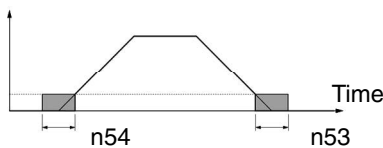
| Parameter No. (Register No. (Hex)) | Name                                      | Description   | Setting range                  | Default setting | Changes during operation | Memo |
|------------------------------------|---|---|--------------------------------|-----------------|--------------------------|------|
| n46<br>(012E)                      | Carrier frequency selection               | Used to set the carrier frequency according to the set values, as follows:<br>1 to 4: Carrier frequency = Set value x 2.5 kHz (fixed)<br>7 to 9: Carrier frequency = Output frequency ratio for 1 kHz to 2.5 kHz maximum, as follows:<br>7: 1.0 to 2.5 kHz (12 times): Output frequency x12<br>8: 1.0 to 2.5 kHz (24 times): Output frequency x24<br>9: 1.0 to 2.5 kHz (36 times): Output frequency x36 | 1 to 4,<br>7 to 9              | 4               | No                       |      |
| n47<br>(012F)                      | Momentary power interruption compensation | Used to specify the processing that is performed when a momentary power interruption occurs.<br>0: Inverter stops operating<br>1: Inverter continues operating if power interruption is 0.5 s or less.<br>2: Inverter restarts when power is restored.  | 0 to 2                         | 0               | No                       |      |
| n48<br>(0130)                      | Fault retry                               | Used to set the number of times the Inverter is reset and restarted automatically in the case the Inverter has an overvoltage fault, overcurrent fault, or ground fault.  | 0 to 10                        | 0               | No                       |      |
| n49<br>(0131)                      | Jump frequency 1                          | Used to set the frequency jump function.<br> <p>The graph shows a step-like increase in output frequency as the frequency reference increases. Three specific points are marked: n50 (start of first jump), n49 (end of first jump), and n51 (start of second jump).</p>   | 0.0 to 400                     | 0.0             | No                       |      |
| n50<br>(0132)                      | Jump frequency 2                          |   | 0.0 to 400                     | 0.0             | No                       |      |
| n51<br>(0133)                      | Jump width                                |   | 0.0 to 25.5                    | 0.0             | No                       |      |
|                                    |   | <b>Note</b> These values must satisfy the following condition: $n49 \geq n50$   |                                |                 |                          |      |
| n52<br>(0134)                      | DC control current                        | Used to impose DC on the induction motor for braking control.<br>Set the DC braking current in percentage based on the rated current of the Inverter as 100%.   | 0 to 100                       | 50              | No                       |      |
| n53<br>(0135)                      | Interruption DC control time              | Output frequency<br> <p>The graph shows a trapezoidal output frequency profile over time. Two shaded regions are indicated: n54 (minimum output frequency) and n53 (time interval).</p>  | 0.0 to 25.5                    | 0.5             | No                       |      |
| n54<br>(0136)                      | Startup DC control time                   |   | Minimum output frequency (n14) | 0.0 to 25.5     | 0.0                      | No   |

| Parameter No. (Register No. (Hex)) | Name                                       | Description   | Setting range | Default setting | Changes during operation | Memo |
|------------------------------------|--|---|---------------|-----------------|--------------------------|------|
| n55<br>(0137)                      | Stall prevention during deceleration       | Used to select a function to change the deceleration time of the motor automatically so that there will be no overvoltage imposed on the motor during deceleration.<br>0: Stall prevention during deceleration enabled<br>1: Stall prevention during deceleration disabled  | 0, 1          | 0               | No                       |      |
| n56<br>(0138)                      | Stall prevention level during acceleration | Used to select a function to stop the acceleration of the motor automatically for stall prevention during acceleration.<br>Set the level in percentage based on the rated current of the Inverter as 100%.  | 30 to 200     | 170             | No                       |      |
| n57<br>(0139)                      | Stall prevention level during operation    | Used to select a function to reduce the output frequency of the Inverter automatically for stall prevention during operation.<br>Set the level in percentage based on the rated current of the Inverter as 100%.  | 30 to 200     | 160             | No                       |      |
| n58<br>(013A)                      | Frequency detection level                  | Used to set the frequency to be detected.<br><b>Note</b> The parameter n40 for multi-function output must be set for the output of frequency detection levels 1 and 2.  | 0.0 to 400    | 0.0             | No                       |      |
| n59<br>(013B)                      | Overtorque detection function selection    | Used to enable or disable overtorque detection and select the processing method after overtorque detection.<br>0: Overtorque detection disabled<br>1: Overtorque detection only when speed coincides and operation continues (issues alarm)<br>2: Overtorque detection only when speed coincides and output shut off (for protection)<br>3: Overtorque always detected and operation continues (issues alarm)<br>4: Overtorque always detected and output shut off (for protection) | 0 to 4        | 0               | No                       |      |
| n60<br>(013C)                      | Overtorque detection level                 | Used to set overtorque detection level.<br>Set the level in percentage based on the rated current of the Inverter as 100%.  | 30 to 200     | 160             | No                       |      |
| n61<br>(013D)                      | Overtorque detection time                  | Used to set the detection time of overtorque.   | 0.1 to 10.0   | 0.1             | No                       |      |

| Parameter No. (Register No. (Hex)) | Name                             | Description   | Setting range | Default setting           | Changes during operation | Memo |
|------------------------------------|----------------------------------|---|---------------|---------------------------|--------------------------|------|
| n62<br>(013E)                      | UP/DOWN command frequency memory | Used to store the adjusted frequency reference with the UP/DOWN function.<br>0: Frequency not stored<br>1: Frequency stored<br>The frequency must be on hold for 5 s or more.<br>Used to store the adjusted frequency reference with the UP/DOWN function.<br>0: Frequency not stored<br>1: Frequency stored<br>The frequency must be on hold for 5 s or more.<br>Used to store the adjusted frequency reference with the UP/DOWN function.<br>0: Frequency not stored<br>1: Frequency stored<br>The frequency must be on hold for 5 s or more. | 0, 1          | 0                         | No                       |      |
| n63<br>(013F)                      | Torque compensation gain         | Used to set the gain of the torque compensation function.<br>The default setting does not need any changes in normal operation.   | 0.0 to 2.5    | 1.0                       | Yes                      |      |
| n64<br>(0140)                      | Motor rated slip                 | Used to set the rated slip value of the motor in use.<br><b>Note</b> Used as the constant of the slip compensation function.  | 0.0 to 20.0   | Varies with the capacity. | Yes                      |      |
| n65<br>(0141)                      | Motor no-load current            | Used to set the no-load current of the motor in use based on the rated motor current as 100%.<br><b>Note</b> Used as the constant of the slip compensation function.  | 0 to 99       | Varies with the capacity. | No                       |      |
| n66<br>(0142)                      | Slip compensation gain           | Used to set the gain of the slip compensation function.<br><b>Note</b> The slip compensation function is disabled with n66 set to 0.0.  | 0.0 to 2.5    | 0.0                       | Yes                      |      |
| n67<br>(0143)                      | Slip compensation time constant  | Used for the response speed of the slip compensation function.<br><b>Note</b> The default setting does not need any changes in normal operation.  | 0.0 to 25.5   | 2.0                       | No                       |      |

| Parameter No. (Register No. (Hex)) | Name  | Description   | Setting range | Default setting | Changes during operation | Memo |
|------------------------------------|---|---|---------------|-----------------|--------------------------|------|
| n68<br>(0144)<br>(See note 3.)     | RS-422A/485 communications time-over detection selection              | Used to set whether a communications time-over (CE) is detected if there is an interval of more than 2 s, and to select the method of processing the detected communications time-over.<br>0: Detects a time-over and fatal error and coasts to a stop.<br>1: Detects a time-over and fatal error and decelerates to a stop in deceleration time 1.<br>2: Detects a time-over and fatal error and decelerates to a stop in deceleration time 2.<br>3: Detects a time-over and nonfatal error warning and continues operating.<br>4: No time-over is detected. | 0 to 4        | 0               | No                       |      |
| n69<br>(0145)<br>(See note 3.)     | RS-422A/485 communications frequency reference/display unit selection | Used to set the unit of frequency reference and frequency-related values to be set or monitored through communications.<br>0: 0.1 Hz<br>1: 0.01 Hz<br>2: Converted value based on 30,000 as max. frequency<br>3: 0.1% (Max. frequency: 100%)  | 0 to 3        | 0               | No                       |      |
| n70<br>(0146)<br>(See note 3.)     | RS-422A/485 communications Slave address                              | Used to set the Slave address (Slave unit number) for communications.<br>0: Only receives broadcast messages from the Master.<br>01 to 32: Slave address  | 00 to 32      | 00              | No                       |      |
| n71<br>(0147)<br>(See note 3.)     | RS-422A/485 baud rate selection                                       | Used to set the baud rate for communications.<br>0: 2,400 bps<br>1: 4,800 bps<br>2: 9,600 bps<br>3: 19,200 bps  | 0 to 3        | 2               | No                       |      |
| n72<br>(0148)<br>(See note 3.)     | RS-422A/485 parity selection  | Used to set the parity for communications.<br>0: Even parity<br>1: Odd parity<br>2: No parity   | 0 to 2        | 0               | No                       |      |
| n73<br>(0149)<br>(See note 3.)     | RS-422A/485 send wait time  | Used to set the waiting period for returning a response after the DSR (data-send-request) message is received from the Master.  | 10 to 65      | 10              | No                       |      |

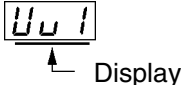

| Parameter No. (Register No. (Hex)) | Name  | Description  | Setting range | Default setting | Changes during operation | Memo |
|------------------------------------|---|--|---------------|-----------------|--------------------------|------|
| n74<br>(014A)<br>(See note 3.)     | RS-422A/485 RTS control selection               | Select whether or not to enable the RTS (request-to-send) communications control function.   | 0, 1          | 0               | No                       |      |
| n75<br>(014B)                      | Low-speed carrier frequency reduction selection | Used to select a function to reduce the carrier frequency when Inverter is at low speed.<br>0: Function disabled<br>1: Function enabled<br><b>Note</b> Normally set n75 to 0.  | 0.1           | 0               | No                       |      |
| n76<br>(014C)<br>(See note 3.)     | Parameter copy and verify function              | Selects the function to read, copy, and verify the parameters between the memory of the Inverter and that of the Digital Operator.<br>rdy: Ready to accept the next command.<br>rED: Reads the Inverter parameters.<br>Cpy: Copies the parameter to the Inverter.<br>vFY: Verifies the Inverter parameters.<br>vA: Checks the Inverter capacity display.<br>Sno: Checks the software number. | rdy to Sno    | rdy             | No                       |      |
| n77<br>(014D)<br>(See note 3.)     | Parameter read prohibit selection               | Selects the copy-prohibit function.<br>Use this parameter to protect the data in the EEPROM of the Digital Operator.<br>0: Read prohibited for Inverter parameters. (Data cannot be written to EEPROM.)<br>1: Read possible for Inverter parameters. (Data can be written to EEPROM.)  | 0, 1          | 0               | No                       |      |
| n78<br>(014E)                      | Error log                                       | Used to display the latest error recorded.<br><br><b>Note</b> “— — —” will be displayed if no error has been recorded.<br><b>Note</b> This parameter is monitored only.   | ---           | ---             | ---                      |      |
| n79<br>(014F)                      | Software number                                 | Used to display the software number of the Inverter for OMRON's control reference use.<br><b>Note</b> This parameter is monitored only.  | ---           | ---             | ---                      |      |

**Note 1.** Values will be set in 0.1-Hz increments if the frequency is less than 100 Hz and 1-Hz increments if the frequency is 100 Hz or over. With RS-422/485 communications, the unit is always 0.1 Hz.

**Note 2.** The n68 to n74, n76, and n77 parameters cannot be written via RS422/485 communications. They are read-only.

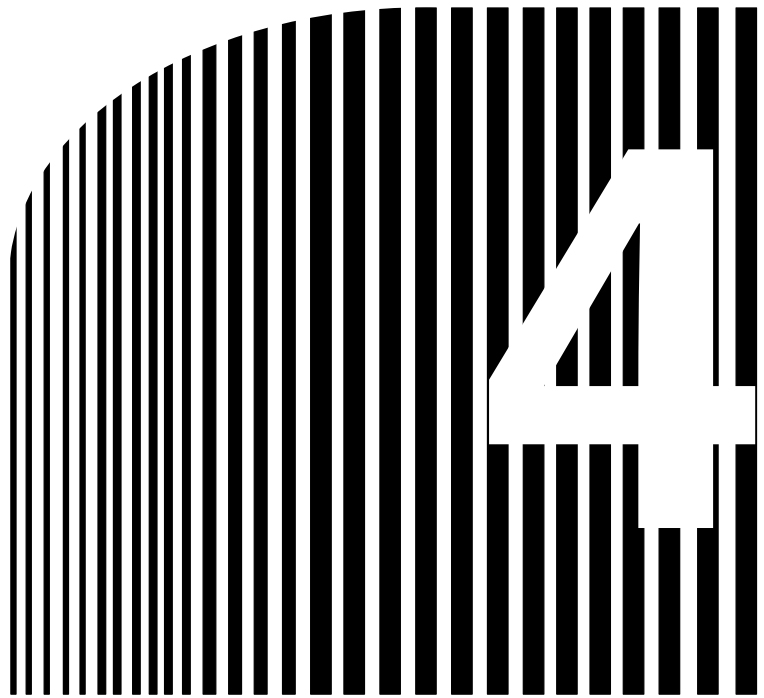

## Chapter 4

### • **Maintenance Operations** •

- 4-1 Protective and Diagnostic Functions
- 4-2 Inspection and Maintenance

## 4-1 Protective and Diagnostic Functions

### 4-1-1 Fault Detection (Fatal Error)

The Inverter will detect the following faults if the Inverter or motor burns or the internal circuitry of the Inverter malfunctions. When the Inverter detects a fault, the fault code will be displayed on the Digital Operator, the fault contact output will operate, and the Inverter output will be shut off causing the motor to coast to a stop. The stopping method can be selected for some faults, and the selected stopping method will be used with these faults. If a fault has occurred, refer to the following table to identify and correct the cause of the fault. Use one of the following methods to reset the fault after restarting the Inverter. If the operation command is being input, however, the reset signal will be ignored. Therefore, be sure to reset the fault with the operation command turned off.

- Turn on the fault reset signal. A multi-function input (n36 to n39) must be set to 5 (Fault Reset).
- Press the STOP/RESET Key on the Digital Operator.
- Turn the main circuit power supply off and then on again.

#### ■ Fault Displays and Processing

| Fault display | Fault name and meaning  | Probable cause and remedy   |
|---------------|---|---|
| oC            | <b>Overcurrent (OC)</b><br>The Inverter output current is as high as or higher than 200% of the rated output current.             | <ul style="list-style-type: none"> <li>• A short-circuit or ground fault has occurred and at the Inverter output.<br/>→ Check and correct the motor power cable.</li> <li>• The V/f setting is incorrect.<br/>→ Reduce the V/f set voltage.</li> <li>• The motor capacity is too large for the Inverter.<br/>→ Reduce the motor capacity to the maximum permissible motor capacity.</li> <li>• The magnetic contactor on the output side of the Inverter has been opened and closed.<br/>→ Rearrange the sequence so that the magnetic contactor will not open or close while the Inverter has current output.</li> <li>• The output circuit of the Inverter is damaged.<br/>→ Replace the Inverter.</li> </ul> |
| oV            | <b>Overvoltage (OV)</b><br>The main circuit DC voltage has reached the overvoltage detection level (100-V models: 410 V DC min.). | <ul style="list-style-type: none"> <li>• The deceleration time is too short.<br/>→ Increase the deceleration time.</li> <li>• The power supply voltage is too high.<br/>→ Decrease the voltage so it will be within specifications.</li> <li>• There is excessive regenerative energy due to overshooting at the time of acceleration.<br/>→ Suppress the overshooting as much as possible.</li> </ul>  |

| Fault display | Fault name and meaning  | Probable cause and remedy  |
|---------------|---|--|
| Uu1           | <p><b>Main circuit undervoltage (UV1)</b><br/>                     The main circuit DC voltage has reached the undervoltage detection level (160 V DC for the 3G3JV-A1□).</p> | <ul style="list-style-type: none"> <li>• Power supply to the Inverter has phase loss, power input terminal screws are loose, or the power cable is disconnected.<br/>                         → Check the above and take necessary countermeasures.</li> <li>• Incorrect power supply voltage<br/>                         → Make sure that the power supply voltage is within specifications.</li> <li>• Momentary power interruption has occurred.<br/>                         → Use the momentary power interruption compensation (Set n47 so that the Inverter restarts after power is restored)<br/>                         → Improve the power supply.</li> <li>• The internal circuitry of the Inverter is damaged.<br/>                         → Change the Inverter.</li> </ul>  |
| oH            | <p><b>Radiation fin overheated (OH)</b><br/>                     The temperature of the radiation fins of the Inverter has reached 110°C ± 10°C.</p>                          | <ul style="list-style-type: none"> <li>• The ambient temperature is too high.<br/>                         → Ventilate the Inverter or install a cooling unit.</li> <li>• The load is excessive.<br/>                         → Reduce the load.<br/>                         → Decrease the Inverter capacity.</li> <li>• The V/f setting is incorrect.<br/>                         → Reduce the V/f set voltage.</li> <li>• The acceleration/deceleration time is too short.<br/>                         → Increase the acceleration/deceleration time.</li> <li>• The ventilation is obstructed.<br/>                         → Change the location of the Inverter to meet the installation conditions.</li> <li>• The cooling fan of the Inverter does not work.<br/>                         → Replace the cooling fan.</li> </ul> |

| Fault display | Fault name and meaning   | Probable cause and remedy  |
|---------------|--|--|
| OL1           | <p><b>Motor overload (OL1)</b><br/>The electric thermal relay actuated the motor overload protective function.</p>   | <ul style="list-style-type: none"> <li>• The load is excessive.<br/>→ Reduce the load.<br/>→ Decrease the Inverter capacity.</li> <li>• The V/f setting is incorrect.<br/>→ Reduce the V/f set voltage.</li> <li>• The value in n11 for maximum voltage frequency is low.<br/>→ Check the motor nameplate and set n11 to the rated frequency.</li> <li>• The acceleration/deceleration time is too short.<br/>→ Increase the acceleration/deceleration time.</li> <li>• The value in n32 for rated motor current is incorrect.<br/>→ Check the motor nameplate and set n32 to the rated current.</li> <li>• The Inverter is driving more than one motor.<br/>→ Disable the motor overload detection function and install an electronic thermal relay for each of the motors. The motor overload detection function is disabled by setting n32 to 0.0 or n33 to 2.</li> <li>• The motor protective time setting in n34 is short.<br/>→ Set n34 to 8 (the default value).</li> </ul> |
| OL2           | <p><b>Inverter overload (OL2)</b><br/>The electronic thermal relay has actuated the Inverter overload protective function.</p>   | <ul style="list-style-type: none"> <li>• The load is excessive.<br/>→ Reduce the load.</li> <li>• The V/f setting is incorrect.<br/>→ Reduce the V/f set voltage.</li> <li>• The acceleration/deceleration time is too short.<br/>→ Increase the acceleration/deceleration time.</li> <li>• The Inverter capacity is insufficient.<br/>→ Use an Inverter model with a higher capacity.</li> </ul>  |
| OL3           | <p><b>Overtorque detection (OL3)</b><br/>There has been a current or torque the same as or greater than the setting in n60 for overtorque detection level and that in n61 for overtorque detection time. A fault has been detected with n59 for overtorque detection function selection set to 2 or 4.</p> | <ul style="list-style-type: none"> <li>• The mechanical system is locked or has a failure.<br/>→ Check the mechanical system and correct the cause of overtorque.</li> <li>• The parameter settings were incorrect.<br/>→ Adjust the n60 and n61 parameters according to the mechanical system. Increase the set values in n60 and n61.</li> </ul>   |
| GF            | <p><b>Ground fault (GF)</b><br/>The ground fault current at the output of the Inverter has exceeded the rated output current of the Inverter.</p>  | <ul style="list-style-type: none"> <li>• A ground fault has occurred at the Inverter output.<br/>→ Check the connections between the Inverter and motor and reset the fault after correcting its cause.</li> </ul>   |

| Fault display | Fault name and meaning  | Probable cause and remedy  |
|---------------|---|--|
| EF□           | <p><b>External fault □ (EF□)</b><br/>                     An external fault has been input from a multi-function input.<br/>                     A multi-function input 1, 2, 3, or 4 set to 3 or 4 has operated. The EF number indicates the number of the corresponding input (S2 to S5).</p> | <ul style="list-style-type: none"> <li>• An external fault was input from a multi-function input.<br/>→ Remove the cause of the external fault.</li> <li>• The sequence is incorrect.<br/>→ Check and change the external fault input sequence including the input timing and NO or NC contact.</li> </ul>   |
| F00           | <p><b>Digital Operator transmission fault 1 (F00)</b><br/>                     An initial memory fault has been detected</p>  | <ul style="list-style-type: none"> <li>• The internal circuitry of the Inverter has a fault.<br/>→ Turn the Inverter off and on.<br/>→ Replace the Inverter if the same fault occurs again.</li> </ul>   |
| F01           | <p><b>Digital Operator transmission fault 2 (F01)</b><br/>                     A ROM fault has been detected.</p>   | <ul style="list-style-type: none"> <li>• The internal circuitry of the Inverter has a fault.<br/>→ Turn the Inverter off and on.<br/>→ Replace the Inverter if the same fault occurs again.</li> </ul>   |
| F04           | <p><b>Initial memory fault (F04)</b><br/>                     An error in the built-in EEPROM of the Inverter has been detected.</p>  | <ul style="list-style-type: none"> <li>• The internal circuitry of the Inverter has a fault.<br/>→ Initialize the Inverter with n01 set to 8 or 9 and turn the Inverter off and on.<br/>→ Replace the Inverter if the same fault occurs again.</li> </ul>  |
| F05           | <p><b>Analog-to-digital converter fault (F05)</b><br/>                     An analog-to-digital converter fault has been detected.</p>  | <ul style="list-style-type: none"> <li>• The internal circuitry of the Inverter has a fault.<br/>→ Turn the Inverter off and on.<br/>→ Replace the Inverter if the same fault occurs again.</li> </ul>   |
| F07           | <p><b>Digital Operator fault (F07)</b><br/>                     An error in the built-in control circuit of the Digital Operator has been detected.</p>   | <ul style="list-style-type: none"> <li>• The internal circuitry of the Digital Operator has a fault.<br/>→ Turn the Digital Operator off and on.<br/>→ Replace the Digital Operator if the same fault occurs again.</li> </ul>   |
| EE            | <p><b>Communications time-over (CE)</b><br/>                     Normal RS-422A/485 communications were not established within 2 s. The Inverter will detect this error if n68 (RS-422A/485 communications time-over detection selection) is set to 0, 1, or 2.</p>                             | <ul style="list-style-type: none"> <li>• A short-circuit, ground fault, or disconnection has occurred on the communications line.<br/>→ Check and correct the line.</li> <li>• The termination resistance setting is incorrect.<br/>→ Set the termination resistance of only the Inverter located at each end of the network to ON.</li> <li>• Noise influence.<br/>→ Do not wire the communications line along with power lines in the same conduit.<br/>→ Use the twisted-pair shielded wire for the communications line, and ground it at the Master.</li> <li>• Master's program error.<br/>→ Check and correct the program so that communications will be performed more than once every 2-s period.</li> <li>• Communications circuit damage.<br/>→ If the same error is detected as a result of a self-diagnostic test, change the Inverter.</li> </ul> |

| Fault display | Fault name and meaning   | Probable cause and remedy  |
|---------------|--|--|
| SFP           | <p><b>Emergency stop (STP)</b><br/>                     An emergency stop alarm is input to a multi-function input. (A multi-function input 1, 2, 3, or 4 set to 19 or 21 has operated.)</p> | <ul style="list-style-type: none"> <li>• An emergency stop alarm is input to a multi-function input.<br/>→ Remove the cause of the fault.</li> <li>• The sequence is incorrect.<br/>→ Check and change the external fault input sequence including the input timing and NO or NC contact.</li> </ul> |
| OFF           | <p><b>Power supply error</b></p> <ul style="list-style-type: none"> <li>• Insufficient power supply voltage</li> <li>• Control power supply fault</li> <li>• Hardware fault</li> </ul>       | <ul style="list-style-type: none"> <li>• No power supply is provided.<br/>→ Check and correct the power supply wire and voltage.</li> <li>• Terminal screws are loosened.<br/>→ Check and tighten the terminal screws.</li> <li>• The Inverter is damaged.<br/>→ Replace the Inverter.</li> </ul>    |

### 4-1-2 Warning Detection (Nonfatal Error)

The warning detection is a type of Inverter protective function that does not operate the fault contact output and returns the Inverter to its original status once the cause of the error has been removed. The Digital Operator flashes and display the detail of the error. If a warning occurs, take appropriate countermeasures according to the table below.

**Note** Some warnings or some cases stop the operation of the Inverter as described in the table.

#### ■ Warning Displays and Processing

| Fault display                | Warning name and Meaning  | Probable cause and remedy   |
|------------------------------|---|---|
| $U$<br>(flashing)            | <b>Main Circuit Undervoltage (UV)</b><br>The main circuit DC voltage has reached the undervoltage detection level (160 V DC for the 3G3JV-A1□).   | <ul style="list-style-type: none"> <li>• Power supply to the Inverter has phase loss, power input terminal screws are loose, or the power line is disconnected.<br/>→ Check the above and take necessary countermeasures.</li> <li>• Incorrect power supply voltage<br/>→ Make sure that the power supply voltage is within specifications.</li> </ul>  |
| $OV$<br>(flashing)           | <b>Main Circuit Overvoltage</b><br>The main circuit DC voltage has reached the overvoltage detection level (100-V models: 410 V DC min.).   | <ul style="list-style-type: none"> <li>• The power supply voltage is too high.<br/>→ Decrease the voltage so it will be within specifications.</li> </ul>   |
| $OH$<br>(flashing)           | <b>Radiation fin overheated (OH)</b><br>The temperature of the radiation fins of the Inverter has reached $110^{\circ}\text{C} \pm 10^{\circ}\text{C}$ .  | <ul style="list-style-type: none"> <li>• The ambient temperature is too high.<br/>→ Ventilate the Inverter or install a cooling unit.</li> </ul>  |
| $[\text{CAL}]$<br>(flashing) | <b>Communications standby (CAL)</b><br>No normal DSR message has been received during RS-422A/4895 communications.<br>The Inverter detects this warning only when RUN command selection (n02) is set to 2 or frequency reference selection (n03) is set to 6. Until the warning is reset, no input other than communications input will be ignored. | <ul style="list-style-type: none"> <li>• A short-circuit, ground fault, or disconnection has occurred on the communications line.<br/>→ Check and correct the line.</li> <li>• The termination resistance setting is incorrect.<br/>→ Set the termination resistance of only the Inverter located at each end of the network to ON.</li> <li>• Master's program error.<br/>→ Check the start of communications and correct the program.</li> <li>• Communications circuit damage.<br/>→ If a CAL or CE error is detected as a result of a self-diagnostic test, change the Inverter.</li> </ul> |
| $OL3$<br>(flashing)          | <b>Overtorque detection (OL3)</b><br>There has been a current or torque the same as or greater than the setting in n60 for overtorque detection level and that in n61 for overtorque detection time. A fault has been detected with n59 for overtorque detection function selection set to 1 or 3.  | <ul style="list-style-type: none"> <li>• The mechanical system is locked or has a failure.<br/>→ Check the mechanical system and correct the cause of overtorque.</li> <li>• The parameter settings were incorrect.<br/>→ Adjust the n60 and n61 parameters according to the mechanical system.<br/>Increase the set values in n60 and n61.</li> </ul>  |



| Fault display            | Warning name and Meaning   | Probable cause and remedy  |
|--------------------------|--|--|
| <i>SEr</i><br>(flashing) | <p><b>Sequence error (SER)</b><br/>A sequence change has been input while the Inverter is in operation.<br/>Local or remote selection is input while the Inverter is in operation.<br/><b>Note</b> The Inverter coasts to a stop.</p>  | <ul style="list-style-type: none"> <li>• A sequence error has occurred.<br/>→ Check and adjust the local or remote selection sequence as multi-function input.</li> </ul>  |
| <i>bb</i><br>(flashing)  | <p><b>External base block (bb)</b><br/>The external base block command has been input.<br/><b>Note</b> The Inverter coasts to a stop.</p>  | <ul style="list-style-type: none"> <li>• The external base block command has been input as multi-function input.<br/>→ Remove the cause of external base block input.</li> <li>• The sequence is incorrect.<br/>→ Check and change the external fault input sequence including the input timing and NO or NC contact.</li> </ul>                                 |
| <i>EF</i><br>(flashing)  | <p><b>Forward- and reverse-rotation input (EF)</b><br/>The forward and reverse commands are input to the control circuit terminals simultaneously for 0.5 s or more.<br/><b>Note</b> The Inverter stops according to the method set in n04.</p>  | <ul style="list-style-type: none"> <li>• A sequence error has occurred.<br/>→ Check and adjust the local or remote selection sequence.</li> </ul>  |
| <i>StP</i><br>(flashing) | <p><b>Emergency stop (STP)</b><br/>The Digital Operator stops operating. The STOP/RESET Key on the Digital Operator is pressed while the Inverter is operating according to the forward or reverse command through the control circuit terminals.<br/><b>Note</b> The Inverter stops according to the method set in n04.</p> | <ul style="list-style-type: none"> <li>• The parameter setting was incorrect.<br/>→ Turn off the forward or reverse command once, check that the n06 parameter setting for STOP/RESET Key function selection, and restart the Inverter.</li> </ul>   |
|                          | <p>The emergency stop alarm signal is input as multi-function input.<br/>A multi-function input 1, 2, 3, or 4 set to 20 or 22 has been used.<br/><b>Note</b> The Inverter stops according to the method set in n04.</p>  | <ul style="list-style-type: none"> <li>• An emergency stop alarm is input to a multi-function input.<br/>→ Remove the cause of the fault.</li> <li>• The sequence is incorrect.<br/>→ Check and change the external fault input sequence including the input timing and NO or NC contact.</li> </ul>   |
| <i>FRn</i><br>(flashing) | <p><b>Cooling fan fault (FAN)</b><br/>The cooling fan has been locked.</p>   | <ul style="list-style-type: none"> <li>• The cooling fan wiring has a fault.<br/>→ Turn off the Inverter, dismount the fan, and check and repair the wiring.</li> <li>• The cooling fan is not in good condition.<br/>→ Check and remove the foreign material or dust on the fan.</li> <li>• The cooling fan is beyond repair.<br/>→ Replace the fan.</li> </ul> |

| Fault display             | Warning name and Meaning  | Probable cause and remedy  |
|---------------------------|---|--|
| <p>EE</p>                 | <p><b>Communications time-over (CE)</b><br/>                     Normal RS-422A/485 communications were not established within 2 s. The Inverter will detect this error if n68 (RS-422A/485 communications time-over detection selection) is set to 0, 1, or 2.</p> | <ul style="list-style-type: none"> <li>• A short-circuit, ground fault, or disconnection has occurred on the communications line.<br/>→ Check and correct the line.</li> <li>• The termination resistance setting is incorrect.<br/>→ Set the termination resistance of only the Inverter located at each end of the network to ON.</li> <li>• Noise influence.<br/>→ Do not wire the communications line along with power lines in the same conduit.<br/>→ Use the twisted-pair shielded wire for the communications line, and ground it at the Master.</li> <li>• Master's program error.<br/>→ Check and correct the program so that communications will be performed more than once every 2-s period.</li> <li>• Communications circuit damage.<br/>→ If the same error is detected as a result of a self-diagnostic test, change the Inverter.</li> </ul> |
| <p>OP1<br/>(flashing)</p> | <p><b>Operation error (OP□)</b><br/>(Parameter setting error)</p>   | <ul style="list-style-type: none"> <li>• The values in n36 through n39 for multi-function inputs 1 through 4 have been duplicated.<br/>→ Check and correct the values.</li> </ul>  |
| <p>OP2<br/>(flashing)</p> |   | <ul style="list-style-type: none"> <li>• The V/f pattern settings do not satisfy the following condition.<br/> <math>n14 \leq n12 &lt; n11 \leq n09</math><br/>                     → Check and correct the set value.</li> </ul>  |
| <p>OP3<br/>(flashing)</p> |   | <ul style="list-style-type: none"> <li>• The rated motor current set in n32 exceeds 150% of the rated output current of the Inverter.<br/>→ Check and correct the value.</li> </ul>  |
| <p>OP4<br/>(flashing)</p> |   | <ul style="list-style-type: none"> <li>• The frequency reference upper limit set in n30 and the frequency reference lower limit set in n31 do not satisfy the following condition.<br/> <math>n30 \geq n31</math><br/>                     → Check and correct the set values.</li> </ul>  |
| <p>OP5<br/>(flashing)</p> |   | <ul style="list-style-type: none"> <li>• The jump frequencies set n49, n50 do not satisfy the following condition.<br/> <math>n49 \geq n50</math><br/>                     → Check and correct the set values.</li> </ul>  |

---

## 4-2 Inspection and Maintenance

---

### ■ Daily Inspection

Check the following items while the system is operating.

- No abnormal noise or vibration in the motor
- No abnormal heat generation
- Output current monitor display is not a higher value than normal
- Cooling fan installed in Inverter is operating normally (models with fans only)

### ■ Periodic Inspection

Check the following items when performing periodic maintenance.

Always wait at least one minute after the power supply has been turned OFF and all the LED indicators have turned OFF before performing maintenance. Touching the terminals immediately after the power is turned OFF may result in electric shock.

- No looseness in terminal screws
- No electroconductive dust or oil mist attached to terminal block or the Inverter's internal parts
- No looseness in Inverter mounting screws
- No accumulation of dirt or dust on cooling fin (heat sink)
- No dust accumulated in the ventilation holes
- No abnormality in external appearance
- Cooling fan in control panel is operating normally  
(Check that there is no abnormal noise or vibration, and that the total ON time has not exceeded the specified value.)

### ■ Periodic Maintenance of Components

The Inverter is constructed from many components, the normal operation of which is required for the essential functionality of the Inverter. Maintenance is required for some of the electronic components depending on the operating conditions. To enable the Inverter to operate normally for a long time, periodic inspection and component replacement must be performed to suit the service life of these components.

(Source: "Instructions for Periodic Inspection of General Purpose Inverter" (JEMA))

The guidelines for periodic inspection depend on the Inverter's installation environment and operating conditions.

The maintenance periods for the Inverter are listed below. Use this to determine when periodic maintenance is required.

The guidelines for periodic maintenance are as follows:

- Cooling fan: 2 to 3 years
- Electrolytic capacitor: 10 years
- Fuse: 10 years

These guidelines are applicable for an operating environment in which the ambient temperature is 40°C, the load rate is 80%, the operating time is 8 hours per day, and the product is installed according to the instructions in the manual.

To extend the maintenance period, it is recommended to lower the ambient temperature and shorten the ON time as much as possible.

**Note** Contact your OMRON sales representative for details on maintenance methods.

# OMRON

## **OMRON Corporation**

FA Systems Division H.Q.

66 Matsumoto

Mishima-city, Shizuoka 411-8511

Japan

Tel: (81)55-977-9181/Fax: (81)55-977-9045

## ***Regional Headquarters***

### **OMRON EUROPE B.V.**

Wegalaan 67-69, NL-2132 JD Hoofddorp

The Netherlands

Tel: (31)2356-81-300/Fax: (31)2356-81-388

### **OMRON ELECTRONICS LLC**

1 East Commerce Drive, Schaumburg, IL 60173

U.S.A.

Tel: (1)847-843-7900/Fax: (1)847-843-8568

### **OMRON IDM Controls**

9510 North Houston, Tx. 770888

U.S.A.

Tel: (1)713-849-1900/Fax: (1)713-849-4666

### **OMRON ASIA PACIFIC PTE. LTD.**

83 Clemenceau Avenue,

#11-01, UE Square,

Singapore 239920

Tel: (65)6835-3011/Fax: (65)6835-2711

---

Note: Specifications subject to change without notice.

Cat. No. I546-E1-01  
0675398-6  
Printed in Japan